



Shiva Scientific Glass Pvt. Ltd.

Shiva Scientific Glass Pvt. Ltd.

**Borosilicate 3.3 Glass
Pilot Plant & Equipment**

www.shivascientificindia.com
www.glasspilotplants.com

BORO-G[®]

We Care Your Share

A GMP, ISO 9001 : 2015, CE Certified Company

ABOUT US



Shiva Scientific Glass Pvt. Ltd. is the leading ISO 9001:2015 certified manufacturer company engaged in manufacturing of borosilicate glass 3.3 industrial process equipment/process plants in India, for the chemical industry growing at rapid pace.

The company was established in 1999 by Mr Shivaprasad Nair (CMD) with a vision of setting up one reliable source of the complete range of industrial glass for chemical industry with the highest quality and affordable price. In two decades of its existence, the company has proved to be a reputed source of high-quality glassware with unmatched service of international standards.

The company has achieved consistent progress every year since inception based on the large numbers of satisfied customers who buy exclusively from us. We are also the largest OEM supplier to the glass industry; we have now entered into the international markets and have received excellent response from all over the world.

Our products are built for batch and semi-batch mode operations of perfectly matched components of top quality materials which guarantee economical and high-performance solutions tailored to customer requirements.

An R&D as well as pilot plants, Kilo-labs and API Processing companies, our equipment especially Reactor Assemblies are used for multiple processes as batch reactors. The operation temps of such Systems can be -50°C to $+300^{\circ}\text{C}$. These reactors can be used for scale-up processes because of maintained L/D Ratio.



Quality Assurance:

Preventing mistakes or defects in manufactured Products and avoiding Problems when delivering materials & services to the customers.



Mission :

Low Cost Producer, Outstanding customer service.



Vision :

The Growth of our company will be built on our solid foundation.



Goal :

Driving Customer Success, Performing together & Respecting Each Other.



ORGANIZATION

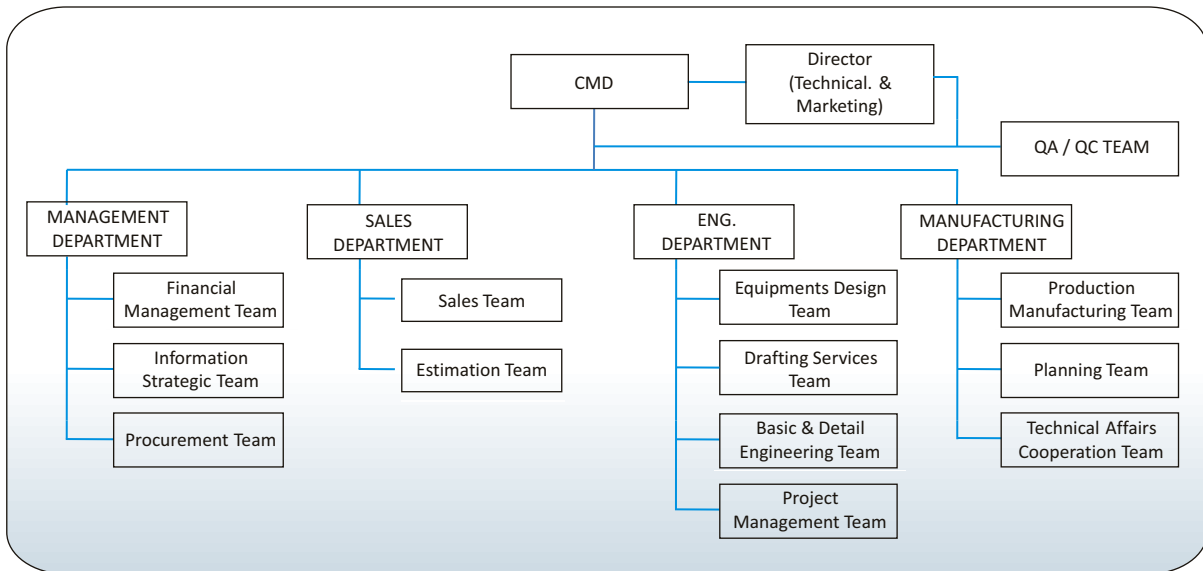

Technology First

Safety First

Customer-First

and Specialized in Scientific Glass-protection against CORROSION

Quality First



PIPELINE COMPONENTS
Page - 07 to 15



STRUCTURE AND SUPPORTS
Page - 54 to 61



VALVES
Page - 16 to 18

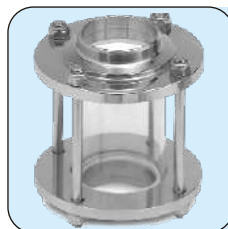

SIGHT GLASS
Page - 62

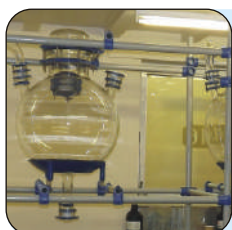

VESSELS
Page - 19 to 27



STANDARD UNITS
Page - 63 to 73



STIRRERS
Page - 28 to 31



TECHNICAL PACKAGES
Page - 74 to 82



HEAT EXCHANGERS
Page - 32 to 38



ROTARY FILM EVAPORATOR
2 TO 100 LITERS
Page - 83 to 86



COLUMN COMPONENTS
Page - 39 to 48



LABORATORY GLASSWARE & APPARATUS
Page - 87 to 89



COUPLINGS & GASKETS
Page - 49 to 53

GENERAL INFORMATION

FAST AVAILABLE ITEMS

Items which are available faster are marked by * in the catalogue. Though it does not indicate any definite period of delivery, these items can be manufactured faster than the other items of its range. For example, Pipe section PS18/1000 can be supplied faster than any other pipe section of 450DN. This is because of following reasons :

- Semi finish goods or raw material for these items will be always available.
- Method of production of these items are set.
- Being fast moving items, these items may be available ex-stock with us.

REPAIRS

Though any damaged glass equipment can be repaired, mostly it is not economical to do so. Generally, the repair which involves less than one third of its original work, is worth to carry out repairing. Repair work is costly because :

- a. It generally require greater skill than making a new one.
- b. Since it involves high risk of total breakage, the risk of total loss of time spent on its repairing goes along with.
- c. The work involved in receiving a damaged equipment, identifying it throughout the handling, cleaning it, estimating its repairing charges, re-estimating the repairing charges in case damage extends etc are relatively expensive.
- d. Each job require individual attention throughout the execution.

However, while sending an equipment for repairing, following care must be taken :

- a. Inform the nature of breakage and get an estimate of repairing charges in advance to avoid the loss of transportation expenses in case it is uneconomical to go for repairing.
- b. Since repairing takes longer time to fit into production schedules and completion of repairing is highly uncertain, it is generally suggested to arrange for a substitute equipment to continue the work.
- c. Equipment to be repaired should be clean. Since it can be cleaned better and at less cost at owner's premises, it should be cleaned before sending it for transportation. This also makes it safer to transport.
- d. Pack with extra care, since cracks in glass have a tendency to extend with every jerk.
- e. If possible, send broken pieces along with it.
- f. Generally repairing work is accepted only for the equipment manufactured by us, and are repaired at owner's risk only.

DIMENSIONS, WEIGHTS AND SPECIFICATIONS

In this catalogue, dimensions, weights and other specifications are taken more or less in accordance with Corning. This is to keep the flexibility of maximum interchange ability. However, some difference are unavoidable due to local manufacturing conditions. All the odd dimensions are rounded off.

All the dimensions and weights are approximate. The specifications given in the catalogue are intended to present a general description of the items. Since manufacturing of glass equipment involves all manual operations, certain tolerances are obvious and permissible while passing the items through quality control.

CATALOGUE REFERENCES

To avoid queries and delays in delivery, please always quote the catalogue reference in your order.

MODIFICATIONS

We reserve the right to carry out technical modifications of products and data mentioned in this catalogue as and when require.

STANDARDS PRACTICED

DIN ISO	3585
DIN ISO	3586
DIN ISO	3587
DIN ISO	4704
BSEN	1595
DIN ISO	718

Terms & Conditions of Business at SSGPL

* Prices offered are Ex-works, new delhi unless otherwise stated.

* Packing & forwarding cost will be charged extra.

* Insurance if desired, to be arranged by the buyer. However, in case of damage of goods in transit due to any reason whatsoever, the buyer has to make relevant claims from the insurance company. We implement the best practices for packing the glass product manufactured by us since more than 45 years.

* We assure and maintain the delivery terms as stated in quotation/offer. However, due to circumstances beyond control, especially in manufacturing of glass, the delivery may vary subject to circumstances.

* The warranty offered against manufacturing defect is upto 12 months from the date of Invoice but parts subject to wear & tear are excluded from warranty.

* In case of a complaint/damages of goods if any, the incident must be notified to us immediately upon receipt of material. Any claim beyond 7 days after receipt of the material shall not be entertained.

* In case of damages proved due to our fault, we shall only be liable for the cost of item as per invoice value only. Any compensation arising due the damage/shortage shall not be applicable.

* If the consignment is held back and not dispatched from our plant beyond delivery period due to any reason at customer's end, the warehousing charges @ INR 10 per square Feet per week shall be paid by the customer towards storage and warehousing charges. (Square Foot Area shall be worked-out as per size of all the packed Cartons and the area covered by the total consignment)

* In case of delay in installation / commissioning due to the reason at customer's end/site for more than 3 months from the date of Invoice, the customer has to release the pending payment held against "Installation/Commissioning".

* An equipment already supplied by SSGPL, if being sent to our works for repair/maintenance purposes, Customer is required to thoroughly clean the equipment before dispatch.

* Advance payment once received against an order is non-refundable, in case of cancellation of order for any reason.

All matters in case disputes is subject to new delhi Jurisdiction.

TECHNICAL INFORMATION

Borosilicate glass represents unmatched standardized glass for construction of plant and piping in the chemical, dyestuff, food pharmaceutical, petrochemical industries. Its steadily growing use is due to many advantages over conventional materials.

- Outstanding corrosion resistance
- Smooth pore free surface
- Transparency
- Catalytic inertness.
- No effect on taste and odour
- Physiological inertness.

Borosilicate glass is chosen for its unique chemical and physical properties. Borosilicate glass can be considered as being composed of Oxides, Silica (SiO₂) Magnesia (MgO) and Lead oxide (PbO) are the principle modifiers/fluxes.

The chemical and physical properties of any glass depends on a varying degree on chemical composition of glass.

CHEMICAL COMPOSITION

The composition of borosilicate glass used for chemical plants has following approximate composition.

SiO ₂ - 80.6%	B ₂ O ₂ - 12.5%
Na ₂ O - 4.2%	Al ₂ O ₃ - 2.2%

RESISTANCE TO CHEMICAL

Borosilicate glass is inert to almost all materials except Hydroflouric acid (HF) Phosphoric acid(H₃PO₄) and hot strong caustic solutions. Of these. Hydroflouric acid has the most serious effect, even when it is present in PPM (parts per million) in solutions. Where as phosphoric acid and caustic solutions cause no problems when cold but at elevated temperature corrosion occurs. In case of caustic solutions, upto 30% concentration can be handled safely at ambient temperature.

Under actual operating conditions, the effect of turbulence, and traces of other chemicals in the solution may increase or decrease the rate of attack. So it is not possible to give exact figures for corrosion by caustic solutions.

PHYSICAL AND THERMAL PROPERTIES

Linear coefficient of thermal expansion

The coefficient of thermal expansion of borosilicate glass over the temperature 0-300°C is 3.3 x 10⁻⁶/°C. This is very low when compared with other glasses and metals. That is why, borosilicate glass is often called low expansion borosilicate glass.

Specific heat

Specific heat between 25°C and 300°C is average to be 0.233Kcal/Kg, °C

Thermal Conductivity

Thermal conductivity is 1.0 Kcal/hr,m°C. Over the permissible operating temperature range.

Mean Specific Heat

Mean specific heat capacity between 20°C and 200°C is 0.98 KJ/Kg K.

DENSITY

Density of glass at 20°C (J)=2.23g/cc
Modulus of elasticity (E)=6.3 KN/mm²
Poissons ratio=0.2

ANNEALING

Annealing of glass is the process where the glass is heated and kept for a defined period of time to relieve internal stresses. Careful cooling under controlled conditions is essential to ensure that no stresses are reintroduced by chilling/cooling.

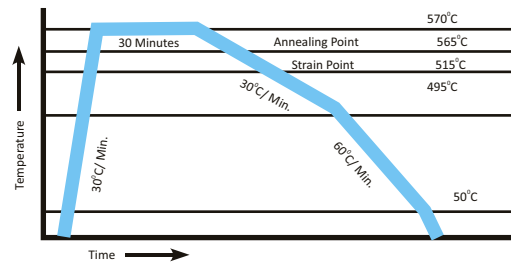

RESHAPING

In the below given table, it shows characteristic temperature at a determined viscosity, essential for glass reshape.

Lower cooling temperature	10 ²¹ poise	515°C
Upper cooling temperature	10 ¹³ poise	565°C
Softening point	10 ⁷ poise	795°C
Reshaping point	10 ⁴ poise	120°C

MECHANICAL PROPERTIES

The lack of ductility of glass prevents the equalization of stresses at local irregularities or flaws and the breakage strength varies considerably about a mean value. This latter is found to occur at a tensile strength of about 700kg/cm² In order to allow for the spread of breaking stress, a large factor of safety is applied when determining the wall thickness requirement to allow operation up to values given in the table of working pressure.

OPTICAL PROPERTIES

Borosilicate glass show no appreciable absorption in the visible region of spectrum and therefore appears clear and colorless.

In photo chemical processes, the transparency of ultra violet is of particular importance. It follows from the transmittance of material in uv region that photo chemical reactions such as Chlorination & Sulpho Chlorination can be performed in it.

TECHNICAL INFORMATION

PERMISSIBLE OPERATING CONDITIONS

Working Pressure For Glass Pipelines & Vessels

The permissible internal operation pressure depends upon the nominal diameter of the glass components and on working temperature.

In case of unit with various combination like vessels, filters, heat exchangers, the over all permissible internal gauge pressure is always governed by the component with the lowest permissible operating gauge pressure all components are suitable for full vacuum.

Bar is a measure of absolute pressure. The figure given for maximum recommended working pressure represents pressure above atmospheric.

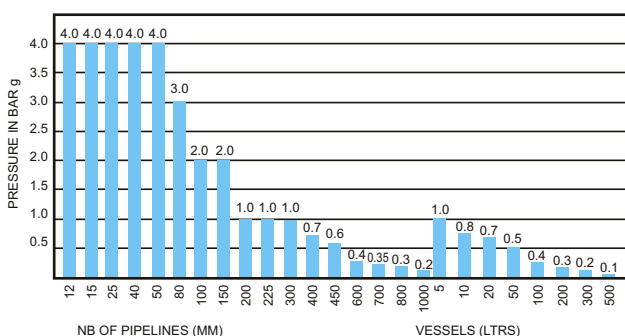

Working Temperature

Borosilicate glass retains its mechanical strength and will deform only at temperature which approach its strain point. The practical upper limit for operating temperature is much lower and is controlled by the temperature differentials in the glass which depends on the relative temperature of the contents of the equipment and the external surroundings. Provided borosilicate glass is not subject to rapid change in temperature, creating undue thermal shock, it can be operated safely at temperatures upto 250°C

It must be realised that in complete plants, composed not only of borosilicate glass, but also include other materials such as PTFE. The recommended max. operating temperature is 200°C. Operating temperatures may have to be modified so as to compensate for the effects of other factors such as pressure, thermal cycling, rapid heating & cooling etc.

The degree of thermal shock (usually defined as sudden chilling or heating) which it can withstand depends on many factors such as stresses due to operating conditions, stresses imposed in supporting the equipment, the wall thickness of the glass. It is therefore undesirable to give sudden temperature changes. But up to 120°C can be accommodated.

As sub zero temperature, the tensile strength of borosilicate glass tends to increase and equipment can be used safely at temperatures as low as -50°C for XTRONG and components.

ELECTRICAL CHARACTERISTICS

Glass being a poor electrical conductor, surface, conductivity is insignificant and varies with the quantity of water absorbed on glass surface. The specific conductivity is 10⁹ohm/cm at temperature of 200°C. The dielectric coefficient varies with current frequency.

COMPOSITE MATERIALS

The last two decades have seen the new or further developments of particularly corrosion resistant plant construction materials. Typical examples of these are PTFE, tantalum, titanium, graphite and of course, Borosilicate 3.3 Glass.

The combination of different corrosion resistant materials with the utilization of the specific advantages of each permits both safe and economic construction.

Borosilicate glass/PTFE

Borosilicate Glass with PTFE is of particularly decisive importance for construction of glass installation For example. in Seals, Bellows, Stirrers, Pumps, Heat Exchangers, Column Inserts etc.

PTFE is used with Glass because of its excellent mechanical & thermal properties. They have near universal fluid compatibility. Wear life when compared with others is very low. Particularly PTFE is maintenance free and have cryogenic stability with non wetting property.

Service temperature of PTFE is considered as -50°C to +200°C

TIGHTENING TORQUE

Diameter	Maximum bolt-tightening torque* in Nm for couplings with backing flanges	
	Made of Plastic (K)	Made of Iron/steel/ Silumin(S)
12	1	1
15	1	1
25	2.5	2.5
40	2.5	3.5
50	2.5	3.5
80	2.5	3.5
100	3.5	4.5
150	3.5	4.5
200	-	4.5
225	-	4.5
300	-	4.5
400	-	6.5
450	-	6.5
600	-	11
700	-	20
800	-	20
1000	-	22

*The Indicated Tightening torques apply for ungreased bolts and are required only for the maximum operating pressures. They can be reduced.

MAJOR ACHIEVEMENTS & PROJECTS - DOMESTICALLY & INTERNATIONALLY

- Started as North India's first Industrial Glass industry to produce complete range of Borosilicate Glass Pilot Plants and Equipment.
- Started Full-Fledged Borosilicate Glass Process Manufacturing unit at G.I.D.C., Makarpura, Vadodara (Gujarat).
- First ISO 9001-2015 Certified & CE Approved organization in the BOROSILICATE 3.3 GLASS Industrial Equipment manufacturing segment in North India.
- Successfully executed 1000 LTR. SS REACTOR WITH overhead GLASS HEAT EXCHANGER ASSEMBLY at MOSER BAER, Greater Noida on a turnkey basis
- Successfully Designed, Developed, Supplied and Commissioned Pilot Scale Bio-Diesel Generation Unit for First time in India at Indian Oil Corporation Ltd. (IOCL) Faridabad (Haryana)
- Participated inACHEMA-2012 at Frankfurt, Germany as the borosilicate glass equipment manufacturer from India.
- Entered into Manufacturing International quality LABORATORY GLASSWARE & GLASS APPARATUS under the Brand name 'BORO-G.
- Participated "ARAB LAB' Exhibition at Dubai
- Successfully commissioned GOLD REFINERY PROJECT at Haridwar (Uttarakhand State)
- Achieved major fabrication order for specialized Laboratory Glassware from AIMER
- CHEMICAL PROCESS PLANT LTD., UK (Largest fabricator & supplier of QVF & SCHOTT model glass assemblies & equipment) PRODUCTS LTD., Brimsdown, UK. As their OEM supplier.
- Large Contract received for the supply of GLASS AND NON-GLASS EQUIPMENT to DMK
- One of the single largest orders from Poland for Glass Reflux Reaction Cum Distillation
- Units 300 Ltr. Capacity – 25 Units, 200 Ltr. – 8 Units, 100 Ltr. x 10 Units, HCL Gas Generation Units 50 Ltr. capacity x 2 Units, Simple Distillation Units 200 Ltr. capacity x 6 Units, ROTARY FILM EVAPORATOR 20 Ltr. Capacity x 2 units.
- Recently supplied and successfully commissioned Glass based Ethanol Purification & separation plant at Canada.
- ESSENTIAL OIL Project (Consultancy & Turn-key basis) – with the supply of Fractional Distillation Unit, Short path Distillation & Solvent Distillation units successfully supplied and commissioned at Jakarta (Indonesia)
- Complete Design, Supply and execution of 5 Nos. Glass Shell and Tube Heat Exchanger with 25 Sq. mtr. Heat Transfer area commissioned at USA
- Approved and authorized supplier of INDIAN INSTITUTE OF CHEMICAL TECHNOLOGY (IICT-CSIR), Tarnaka, Hyderabad, for Glass Jacketed Kilo-Lab units.

PIPELINE COMPONENTS



Borosilicate 3.3 glass pipeline offer many advantages for its use in chemical, pharmaceutical industries together with precious metal refining, dye works & electroplating because of its following characteristics.

1. Inert to almost all chemicals, hence no risk of contamination and no unwanted flavours or colours are imparted into product.
 2. Transparency allows visual monitoring of the process, flow patterns, colour changes etc.
 3. Almost universal resistance to corrosion. Long service life is guaranteed.
 4. Smooth surface provides low pressure drop.
 5. Smooth surface permits easy cleaning and prevents fouling.
- All the components are suitable for operation under full vacuum conditions.

Pipeline Components are available from DN 15 to DN 800.
DN 1000 pipeline parts are available on request.

PIPELINE COMPONENTS

PIPE SECTIONS

DN	12	15	25	40	50
L	Cat.Ref.	Cat.Ref.	Cat.Ref.	Cat.Ref.	Cat.Ref.
100	PS0.5/100	PS0.7/100	PS1/100*	PS1.5/100*	PS2/100*
150	PS0.5/150	PS0.7/150	PS1/150*	PS1.5/150*	PS2/150*
200	PS0.5/200	PS0.7/200	PS1/200*	PS1.5/200*	PS2/200*
250	PS0.5/250	PS0.7/250	PS1/250	PS1.5/250	PS2/250
300	PS0.5/300	PS0.7/300	PS1/300*	PS1.5/300	PS2/300
400	PS0.5/400	PS0.7/400	PS1/400	PS1.5/400	PS2/400
500	PS0.5/500	PS0.7/500	PS1/500*	PS1.5/500	PS2/500
600	PS0.5/600	PS0.7/600	PS1/600	PS1.5/600	PS2/600
750	PS0.5/750	PS0.7/750	PS1/750	PS1.5/750	PS2/750
900	PS0.5/900	PS0.7/900	PS1/900	PS1.5/900	PS2/900
1000	PS0.5/1000	PS0.7/1000	PS1/1000*	PS1.5/1000*	PS2/1000*

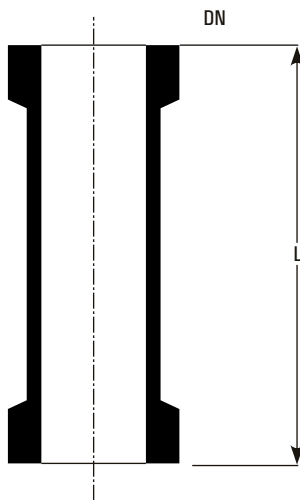

DN	80	100	150
L	Cat.Ref.	Cat.Ref.	Cat.Ref.
150	PS3/150	PS4/150	PS6/150
200	PS3/200	PS4/200	PS6/200
250	PS3/250	PS4/250	PS6/250
300	PS3/300	PS4/300	PS6/300
400	PS3/400	PS4/400	PS6/400
500	PS3/500	PS4/500	PS6/500
600	PS3/600	PS4/600	PS6/600
750	PS3/750	PS4/750	PS6/750
900	PS3/900	PS4/900	PS6/900
1000	PS3/1000*	PS4/1000*	PS6/1000*

DN	225	300	400
L	Cat.Ref.	Cat.Ref.	Cat.Ref.
300	PS9/300	PS12/300	PS16/300
400	PS9/400	PS12/400	-
500	PS9/500	PS12/500	PS16/500
600	PS9/600	PS12/600	-
750	PS9/750	PS12/750	PS16/750
900	PS9/900	PS12/900	-
1000	PS9/1000*	PS12/1000*	PS16/1000
1200	PS9/1200	PS12/1200	PS16/1200
1500	PS9/1500	PS12/1500	PS16/1500

DN	450	600	800	1000
L	Cat.Ref.	Cat.Ref.	Cat.Ref.	Cat.Ref.
300	PS18/300	-	-	-
500	PS18/500	PS24/500	PS32/500	PS40/500
750	PS18/750	-	-	-
1000	PS18/1000	PS24/1000	PS32/1000	PS40/1000
1200	PS18/1200	-	-	-
1500	PS18/1500*	PS24/1500*	PS32/1500	-

* marked items are available fast.

PIPELINE COMPONENTS

SPACERS

Spacers are used to make-up small increments in length.

DN	12	15	25	40	50
L	Cat.Ref.	Cat.Ref.	Cat.Ref.	Cat.Ref.	Cat.Ref.
5	SS0.5/5	SS0.7/5	SS1/5	SS1.5/5	SS2/5
15	SS0.5/15	SS0.7/15	SS1/15	SS1.5/15	SS2/15
25	SS0.5/25	SS0.7/25	SS1/25	SS1.5/25	SS2/25

* L= 50 DN or other size available on request.

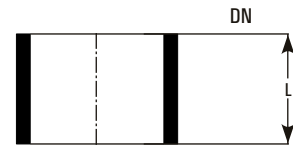

PTFE SPACERS

DN	12	15	25	40	50
L	Cat.Ref.	Cat.Ref.	Cat.Ref.	Cat.Ref.	Cat.Ref.
5	SST0.5/5	SST0.7/5	SST1/5	SST1.5/5	SST2/5
10	SST0.5/10	SST0.7/10	SST1/10	SST1.5/10	SST2/10
15	SST0.5/15	SST0.7/15	SST1/15	SST1.5/15	SST2/15
20	SST0.5/20	SST0.7/20	SST1/20	SST1.5/20	SST2/20

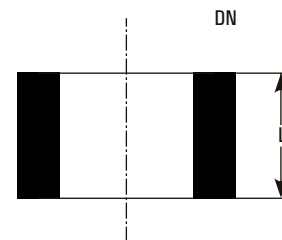

EQUAL TEES

Cat.Ref.	DN	L
PT0.5	12	50
PT0.7	15	50
PT1*	25	100
PT1.5*	40	150
PT2*	50	150
PT3	80	200
PT4	100	250
PT6	150	250
PT9	225	375
PT12	300	450

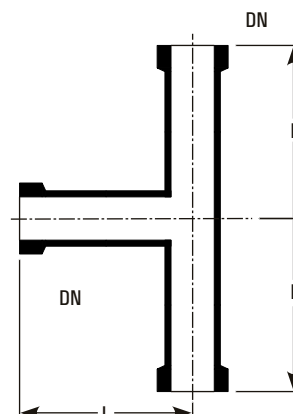

* marked items are available fast.

PIPELINE COMPONENTS

UNEQUAL TEES

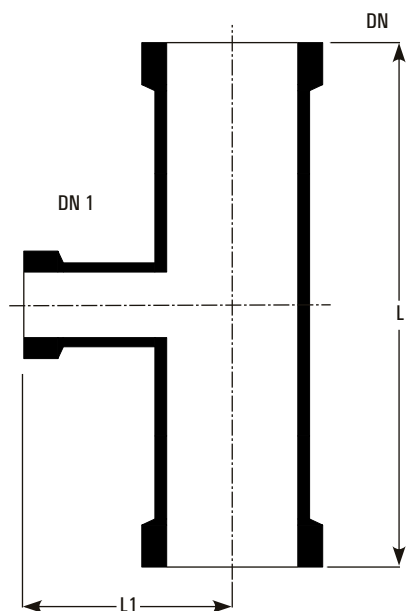

Cat.Ref.	DN	DN1	L	L1
PTU1/0.5	25	12	150	75
PTU1/0.7	25	15	150	75
PTU1.5/1	40	25	200	75
PTU2/1	50	25	200	80
PTU2/1.5	50	40	200	100
PTU3/1	80	25	250	100
PTU3/1.5	80	40	250	100
PTU3/2	80	50	250	115
PTU4/1	100	25	250	110
PTU4/1.5	100	40	250	125
PTU4/2	100	50	250	125
PTU4/3	100	80	300	150
PTU6/1	150	25	250	150
PTU6/1.5	150	40	250	150
PTU6/2	150	50	250	150
PTU6/3	150	80	300	175
PTU6/4	150	100	300	200
PTU9/1	225	25	300	185
PTU9/1.5	225	40	300	185
PTU9/2	225	50	300	185
PTU9/3	225	80	300	210
PTU9/4	225	100	450	250
PTU9/6	225	150	450	275
PTU12/1	300	25	400	230
PTU12/1.5	300	40	400	230
PTU12/2	300	50	400	230
PTU12/3	300	80	400	275
PTU12/4	300	100	400	275
PTU12/6	300	150	450	300
PTU12/9	300	225	600	300
PTU16/1.5	400	40	400	275
PTU16/2	400	50	400	275
PTU16/3	400	80	400	300
PTU16/4	400	100	400	300
PTU16/6	400	150	500	350
PTU16/9	400	225	800	450
PTU16/12	400	300	800	450
PTU18/1.5	450	40	400	300
PTU18/2	450	50	400	300
PTU18/3	450	80	400	320
PTU18/4	450	100	400	320
PTU18/6	450	150	600	380
PTU18/9	450	225	800	400
PTU18/12	450	300	800	400
PTU24/4	600	100	600	450
PTU24/6	600	150	600	450
PTU24/9	600	225	800	525
PTU24/12	600	300	800	525

* marked items are available fast.

PIPELINE COMPONENTS

REDUCERS

Cat.Ref.	DN	DN1	L
PR1/0.5	25	12	100
PR1/0.7	25	15	100
PR1.5/1*	40	25	100
PR2/1*	50	25	100
PR2/1.5*	50	40	100
PR3/1*	80	25	125
PR3/1.5*	80	40	125
PR3/2*	80	50	125
PR4/1*	100	25	150
PR4/1.5*	100	40	150
PR4/2*	100	50	150
PR4/3*	100	80	150
PR6/1*	150	25	200
PR6/1.5*	150	40	200
PR6/2*	150	50	200
PR6/3*	150	80	200
PR6/4*	150	100	200
PR9/1*	225	25	250
PR9/1.5*	225	40	250
PR9/2*	225	50	250
PR9/3*	225	80	250
PR9/4*	225	100	250
PR9/6*	225	150	250
PR12/1*	300	25	300
PR12/1.5*	300	40	300
PR12/2*	300	50	300
PR12/3*	300	80	300
PR12/4*	300	100	300
PR12/6*	300	150	300
PR12/9*	300	225	300
PR16/1.5	400	40	350
PR16/2	400	50	350
PR16/3	400	80	350
PR16/4	400	100	350
PR16/6	400	150	350
PR16/9	400	225	350
PR16/12	400	300	350
PR18/1.5	450	40	375
PR18/2	450	50	375
PR18/3	450	80	375
PR18/4	450	100	375
PR18/6	450	150	375
PR18/9	450	225	375
PR18/12	450	300	375
PR24/4	600	100	400
PR24/6	600	150	400
PR24/9	600	225	425
PR24/12	600	300	425

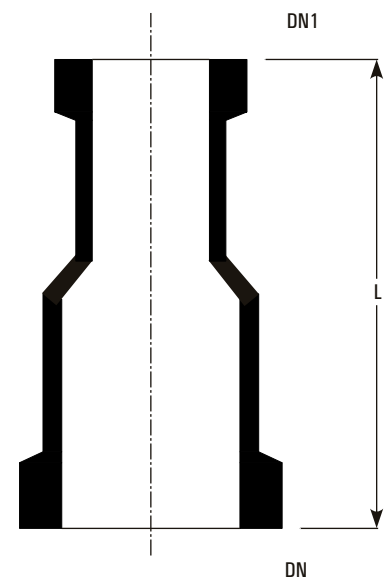

* marked items are available fast.

PIPELINE COMPONENTS

BENDS 90°

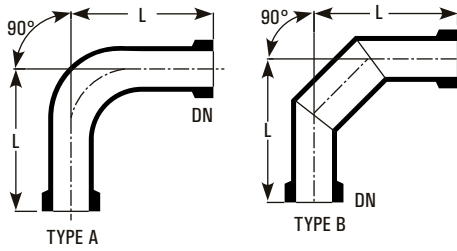

Cat.Ref.	DN	L	TYPE
PB0.5/90	12	50	A
PB0.7/90	15	50	A
PB1/90*	25	100	A
PB1.5/90*	40	150	A
PB2/90*	50	150	A
PB3/90*	80	200	B
PB4/90*	100	250	B
PB6/90*	150	250	B
PB9/90*	225	375	B
PB12/90*	300	450	B

Bends in 80 and 100 degree are also available with same dimensions.
Bends DN 400/DN 450/DN 600 are available on request.

BENDS 45°

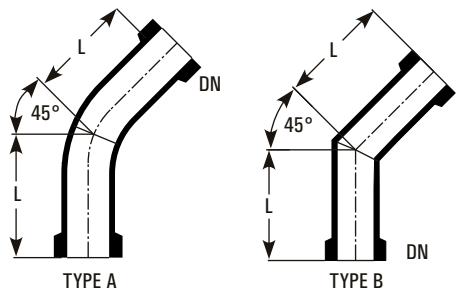

Cat.Ref.	DN	L	TYPE
PB0.5/45	12	50	A
PB0.7/45	15	50	A
PB1/45*	25	75	A
PB1.5/45	40	100	A
PB2/45	50	100	A
PB3/45	80	125	B
PB4/45*	100	175	B
PB6/45	150	250	B
PB9/45	225	375	B

Bends in 10 and 30 degree are also available with same dimensions.

U BENDS

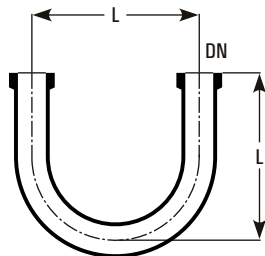

Cat.Ref.	DN	L
PU0.5	12	75
PU0.7	15	75
PU1*	25	150
PU1.5*	40	175
PU2	50	175
PU3	80	225

Y BENDS

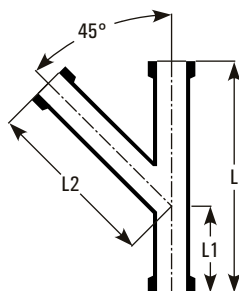

Cat.Ref.	DN	L	L1	L2
PY0.5	12	125	50	80
PY0.7	15	125	50	80
PY1	25	200	75	150
PY1.5	40	250	100	175
PY2	50	300	125	200
PY3	80	350	150	250
PY4	100	450	150	350

BENDS 90° WITH THERMOMETER BRANCH

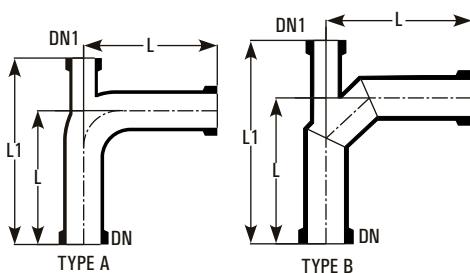

Cat.Ref.	DN	DN1	L	L1	TYPE
PBT1.5	40	25	150	225	A
PBT2	50	25	150	225	A
PBT3*	80	25	200	275	B
PBT4*	100	25	250	325	B
PBT6*	150	25	250	325	B
PBT9*	225	25	375	490	B
PBT12*	300	25	450	560	B

* marked items are available fast.

PIPELINE COMPONENTS

U BENDS WITH BOTTOM OUTLET

Cat.Ref.	DN	DN1	L	L1
PUO0.5	12	12	150	100
PUO1/0.5	25	12	250	150
PUO0.7	15	15	150	100
PUO1/0.7	25	15	250	150
PUO1*	25	25	250	150
PUO1.5*	40	40	275	175
PUO1.5/1*	40	25	275	175
PUO2	50	50	275	175
PUO2/1*	50	25	275	175
PUO3/1	80	25	350	225

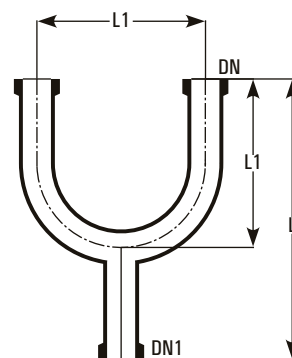

UNEQUAL CROSSES

Cat.Ref.	DN	DN1	DN2	L	L1	L2
PXU2/1/1	50	25	25	200	80	80
PXU2/1.5/1	50	40	25	200	100	80
PXU3/1/1	80	25	25	250	100	100
PXU3/1.5/1	80	40	25	250	100	100
PXU3/2/1	80	50	25	250	115	100
PXU4/1/1	100	25	25	250	110	110
PXU4/1.5/1	100	40	25	250	125	110
PXU4/2/1	100	50	25	250	125	110
PTU4/3/1	100	80	25	300	150	150
PXU6/1.5/1	150	40	25	250	150	150
PXU6/2/1	150	50	25	250	150	150
PXU6/3/2	150	80	50	300	175	150
PXU6/4/2	150	100	50	300	200	150
PXU9/1.5/1.5	225	40	40	300	185	185
PXU9/2/1.5	225	50	40	300	185	185
PXU9/3/1.5	225	80	40	300	210	185
PXU9/4/2	225	100	50	450	250	185
PXU9/6/3	225	150	80	450	275	210
PXU12/2/1.5	300	50	40	400	230	230
PXU12/3/1.5	300	80	40	400	275	230
PXU12/4/1.5	300	100	40	400	275	230
PXU12/6/2	300	150	50	450	300	230
PXU12/9/3	300	225	80	600	300	275
PXU16/1.5/1.5	400	40	40	400	275	275
PXU16/3/1.5	400	80	40	400	300	275
PXU16/4/1.5	400	100	40	400	300	275
PXU16/6/3	400	150	80	500	350	300
PXU16/9/4	400	225	100	800	450	300
PXU18/1.5/1.5	450	40	40	400	300	300
PXU18/3/1.5	450	80	40	400	320	300
PXU18/4/1.5	450	100	40	400	320	300
PXU18/6/3	450	150	80	600	380	320
PXU18/9/4	450	225	100	800	400	320

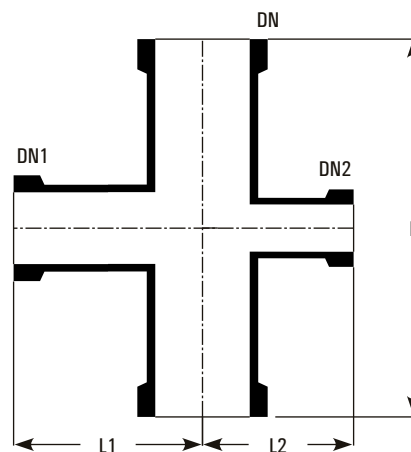

* marked items are available fast.

PIPELINE COMPONENTS

CROSSES

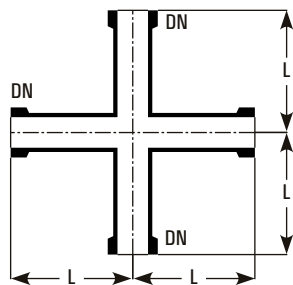

Cat.Ref.	DN	L
PX0.5	12	50
PX0.7	15	50
PX1	25	100
PX1.5	40	150
PX2	50	150
PX3	80	200
PX4	100	250

CLOSURES

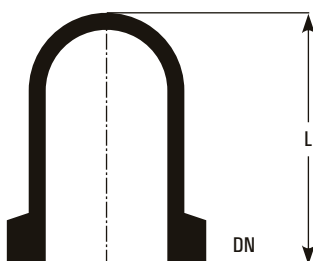

Cat.Ref.	DN	L
PBE0.5	12	40
PBE0.7	15	40
PBE1*	25	50
PBE1.5*	40	75
PBE2*	50	75
PBE3*	80	100
PBE4*	100	125
PBE6*	150	125
PBE9	225	150
PBE12	300	150

BLINDS

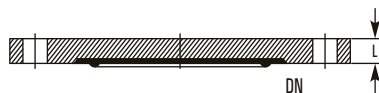

Cat.Ref.	DN	L
PBF1	25	8
PBF1.5	40	8
PBF2	50	8
PBF3*	80	8
PBF4*	100	8
PBF6	150	9
PBF9	225	9
PBF12	300	9

JACKETED PIPE SECTIONS

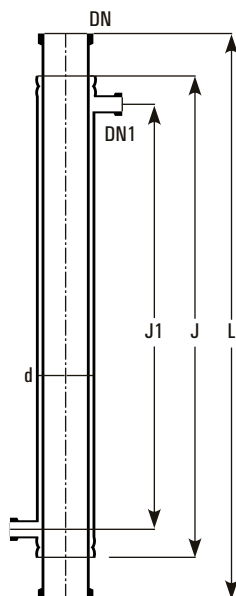

Glass Jackets

For heating of pipe and for controlling the temperature throughout the column, the jacketed pipe sections are provided. Glass jacket is sealed to the pipe section using Viton 'O' ring and other sealing compositions. The seal prevents impermissibly high stresses between two tubes and allows the movement which comes due to thermal expansion. Maximum operating pressure in the jacket :

DN 80 - DN 150
DN 225 - DN 300

1.0 bar
0.5 bar

Cat.Ref.	DN	L	d	DN1	J	J1
PSD3/1000	80	1000	100	25	850	750
PSD4/1000	100	1000	150	25	850	750
PSD6/1000	150	1000	225	25	850	700
PSD9/1000	225	1000	300	25	850	700
PSD12/1000	300	1000	400	25	850	650

PIPELINE COMPONENTS

ADAPTOR PLATE FOR REACTORS

When reactors have a curved end nozzle, these adaptors are used as interface spacer to connect the glass/bellow with reactor.

A flat metal ring with rubber cushions is enveloped with PTFE, to provide ideal sealing. Only PTFE comes in the contact of process fluid.

Cat.Ref.	DN	D	D1	L
EMP1	25	25	60	10
EMP1.5	40	37	80	10
EMP2	50	50	100	10
EMP3	80	75	120	12
EMP4*	100	100	155	12
EMP6*	150	150	210	12
EMP9*	225	200	260	15
EMP12*	300	300	360	15

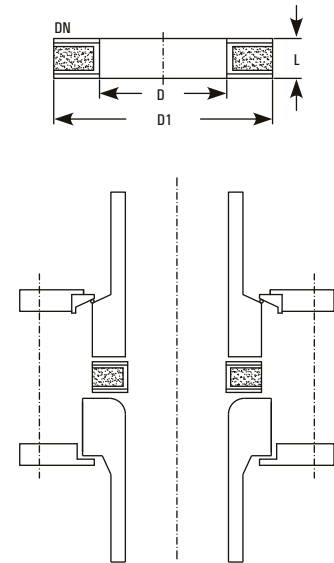

HOSE CONNECTORS

Cat.Ref.	DN	Thread	d	L
PHC0.5/0.25	12	GL14	13.75	70
PHC0.7/0.25	15	GL14	13.75	70
PHC1/1*	25	GL25	24.5	90
PHC1/0.75	25	GL18	17.5	90
PHC1/0.5	25	GL18	17.5	90
PHC1/0.25	25	GL14	13.75	90
PHC1.5/1	40	GL25	24.5	100
PHC1.5/0.75	40	GL18	17.5	100

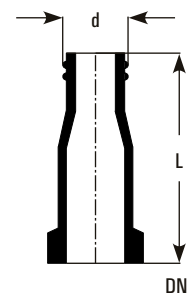

BEND HOSE CONNECTORS

Cat.Ref.	DN	Thread	d	L
PBHC0.5/0.25	12	GL14	13.75	50
PBHC0.7/0.25	15	GL14	13.75	50
PBHC1/1*	25	GL25	24.5	60
PBHC1/0.75	25	GL18	17.5	60
PBHC1.5/0.75	40	GL18	17.5	75
PBHC2/0.75	50	GL18	17.5	100

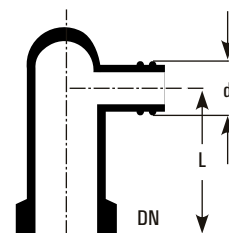

* marked items are available fast.

VALVES



A wide variety of valves are described in this section. All the valves are made of Borosilicate Glass body & PTFE plug so that process fluid just comes in contact with Glass & PTFE only. Borosilicate Glass body permits the visual checking of the operation.

All the valves are suitable for operation under full vacuum conditions & a maximum temperature of 200°C.

Borosilicate Valves are available from DN 15 to DN 50.
Bigger size valves are available on request.

VALVES

STRAIGHT THROUGH VALVES

Cat.Ref.	DN	DN1	d	L	H
PV0.5	12	12	10	125	125
PV0.7	15	15	10	125	125
PV1*	25	25	18	175	175
PV1.5/1	40	25	18	225	175
PV1.5*	40	40	26	225	200
PV2*	50	50	38	300	220

Spindles are made of PTFE.

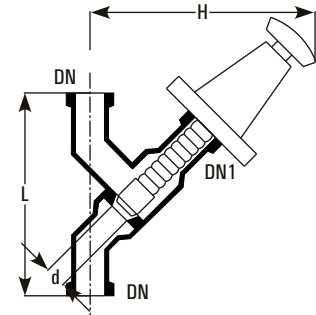

DRAIN VALVES

Cat.Ref.	DN	DN1	d	L	H	D
PVD0.5	12	12	10	125	125	22
PVD0.7	15	15	10	125	125	22
PVD1*	25	25	18	175	175	28
PVD1.5/1*	40	25	18	225	175	28
PVD1.5*	40	40	26	225	200	42
PVD2*	50	50	38	300	220	50

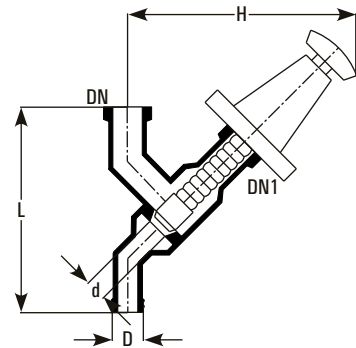

ANGLE VALVES

Cat.Ref.	DN	DN1	d	L	H	Degree
PVE0.5	12	12	10	50	85	90
PVE0.7	15	15	10	50	85	90
PVE1*	25	25	18	100	175	90
PVE1/80*	25	25	18	100	175	80
PVE1.5*	40	40	26	150	200	90
PVE2	50	50	38	150	220	90

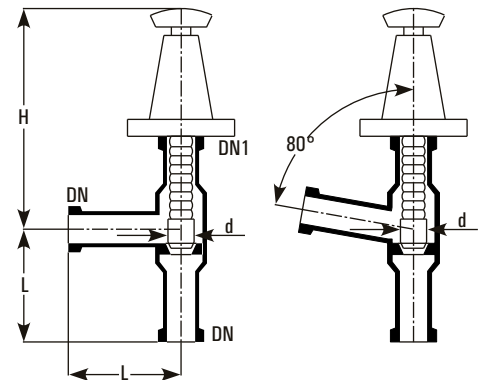

VENT VALVES

Cat.Ref.	DN	D	d	L	L1
PVV0.5	12	12	10	125	90
PVV0.7*	15	12	10	125	90
PVV1*	25	12	10	150	90
PVV1.5*	40	12	10	150	100

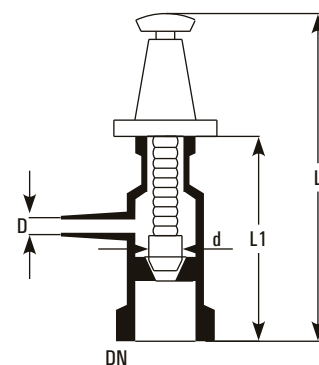

* marked items are available fast.

VENT / VACUUM VALVES

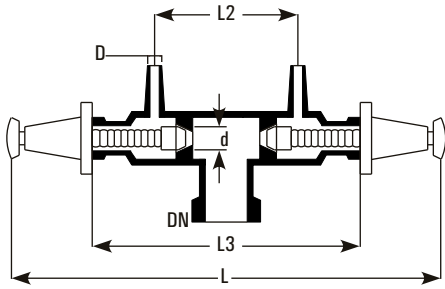

Cat.Ref.	DN	D	d	L	L1	L2	L3
PVW 1/0.7*	25	12	10	280	55	85	160
PVW 1.5/0.7*	40	12	10	280	65	85	160

BOTTOM OUTLET VALVES

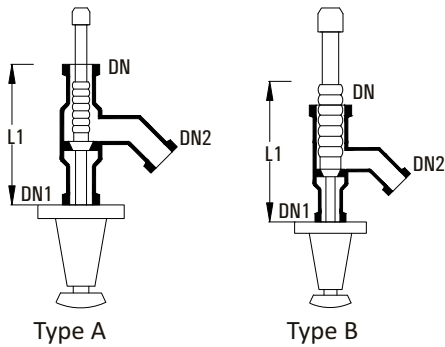

These valves prevent the accumulation of solids or liquid in the bottom outlet of a vessel. This valve can be incorporated in any spherical or cylindrical vessel.

Cat.Ref.	DN	DN1	DN2	L1	Type
BAL1*	25	25	25	150	A
BAL1.5*	40	25	25	150	B
BAL2	50	25	40	150	B

SPACER BOTTOM OUTLET VALVES

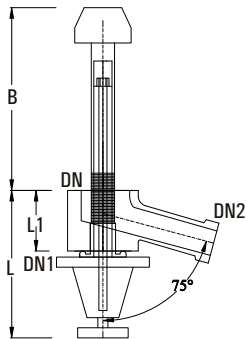

Cat.Ref.	DN	DN1	DN2	L1	L	B
SBAL1	25	25	15	40	110	175
SBAL1.5	40	40	25	60	160	175
SBAL2	50	50	40	60	160	175

WEIGHT OPERATED PRESSURE RELIEF VALVE

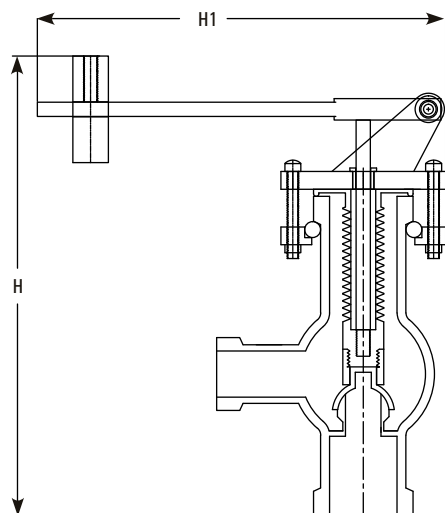

The pressure relief valve (WPRV) is a valve used to control or limit the pressure in a system or vessel which can build up by a process upset, instrument or equipment failure, or fire.

The pressure is relieved by allowing the pressurized gas/fluid to flow out of the system. The pressure relief valve is designed or set to open at a predetermined set pressure to protect Glass vessels and other equipment from being subjected to pressures that exceed their design limits. When the set pressure is exceeded, the pressure relief valve is forced open and a portion of the gas/fluid is released maintaining the required system pressure.

Weight operated pressure relief valve is constructed of glass and PTFE. Sealing of moving parts is effected by a PTFE bellows.

The maximum recommended operating temperature is 150°C and a range of pressure as mentioned below.

It should be installed with the spindle vertical and adequate support should be given.

Model	Size	Pr. range (BAR.g)	Appx. Height (H)	Appx. Width (H1)
WPRV-1.5	DN40	0.4/0.7/0.9	240mm	275mm
WPRV-2	DN50	0.1/0.2/0.3	270mm	275mm

* marked items are available fast.

VESSELS

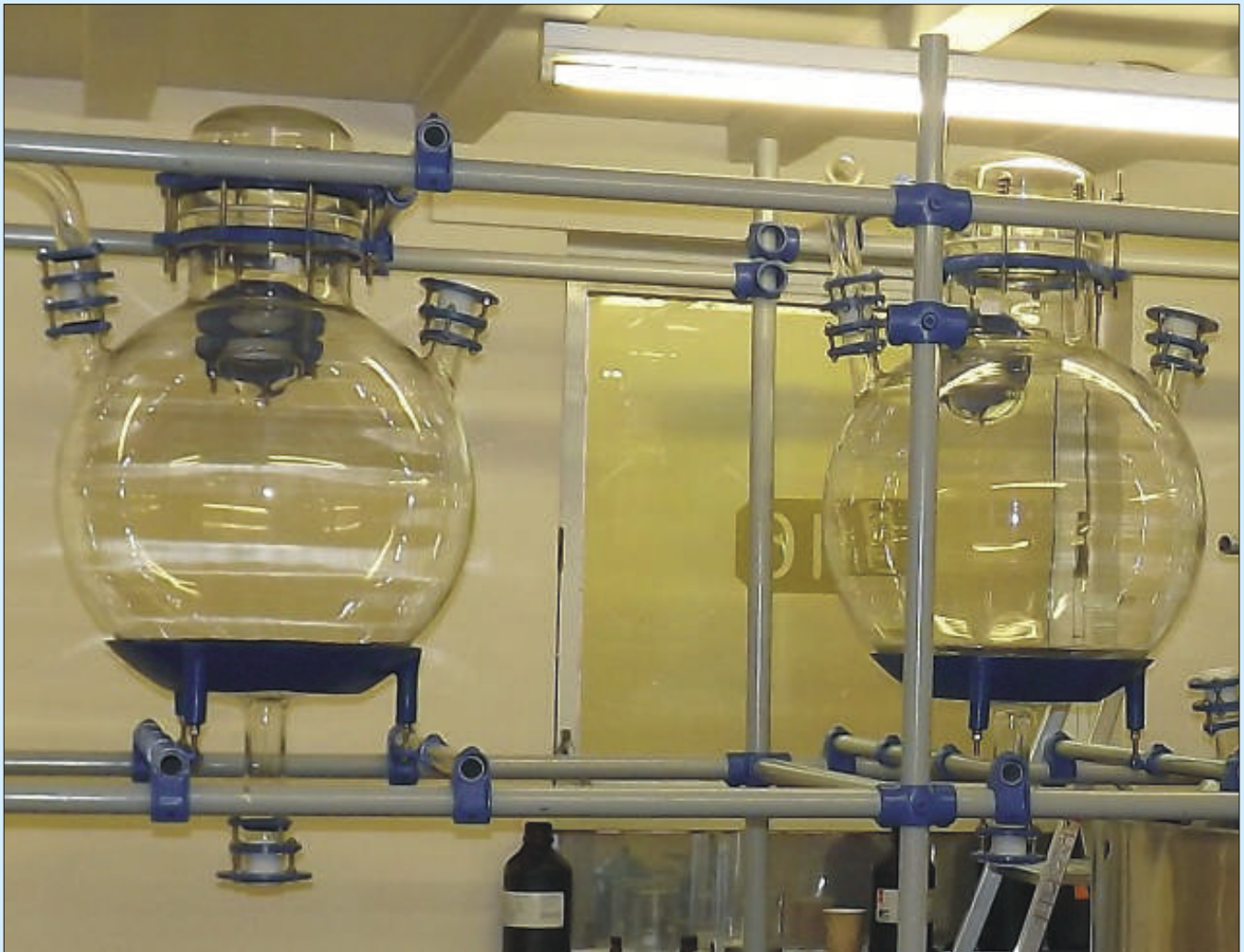

In most of the glass plants, vessels are used as reactors, receivers, separators, measuring or feed vessels.

Vessels are available in Spherical shape from 5Ltr to 500Ltr. & in cylindrical shape from 5Ltr to 800Ltr capacity. Cylindrical vessels can be supplied with glass jackets too.

All the vessels are provided with a bottom outlet for which a suitable valve can be chosen from our range of valves.

SPHERICAL VESSEL - GENERAL DATA

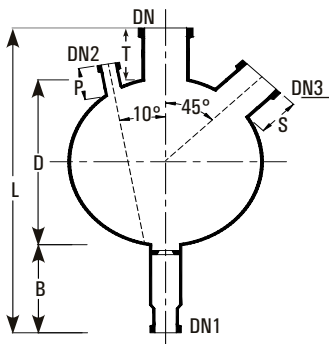
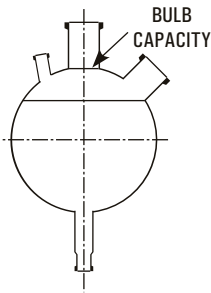

Nominal Capacity (Ltrs.)	Maximum Pressure (Bar)
5	1
10	0.8
20	0.7
50	0.5
100	0.4
200	0.3
300	0.2
500	0.1

Nominal Capacity (Ltrs.)	L	D	DN	T	DN1	B	DN2	P	DN3	S
5	425	225	50	75	25	125	25	50	40	75
10	575	285	80	90	25	200	25	50	40	75
20	650	350	100	100	25	200	25	50	40	75
50	840	490	100	100	40	200	40	75	100	100
50A	840	490	150	150	40	200	40	75	100	100
100	950	600	150	150	40	200	40	75	100	100
100A	950	600	225	150	40	200	40	75	100	100
200	1200	750	225	225	40	200	40	75	100	100
200A	1200	750	300	250	40	200	40	75	100	100
300	1310	860	300	300	50	200	50	75	100	100
300A	1310	860	400	300	50	200	50	75	100	100
500	1450	1000	450	250	50	200	50	75	150	165

SINGLE NECK SPHERICAL VESSELS

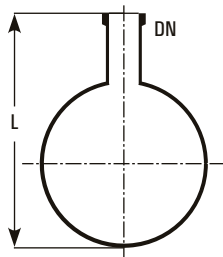

Cat. Ref.	Nominal Capacity	L	DN
VSA5	5 L	300	50
VSA10	10 L	375	80
VSA20	20 L	450	100
VSA50	50 L	640	100
VSA50A	50 L	640	150
VSA100	100 L	750	150
VSA100A	100 L	750	225
VSA200	200 L	1000	225
VSA200A	200 L	1000	300
VSA300	300 L	1110	300
VSA300A	300 L	1110	400
VSA500	500 L	1250	450

THREE NECK BOTTOM OUTLET SPHERICAL VESSELS

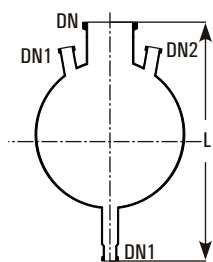

Cat. Ref.	Nominal Capacity	L	DN	DN1	DN2
VSM5	5 L	425	50	25	25
VSM10	10 L	575	80	25	25
VSM20*	20 L	650	100	25	25
VSM50*	50 L	840	100	40	40
VSM50A	50 L	840	150	40	40
VSM100	100 L	950	150	40	40
VSM100A	100 L	950	225	40	40
VSM200	200 L	1200	225	40	40
VSM200A	200 L	1200	300	50	50
VSM300	300 L	1310	300	50	50
VSM300A	300 L	1310	400	50	50
VSM500	500 L	1450	450	50	50

VESSELS

FOUR NECK BOTTOM OUTLET SPHERICAL VESSELS

Cat. Ref.	Nominal Capacity	L	DN	DN1	DN2	DN3
VSPL5	5 L	425	50	25	25	40
VSPL10	10 L	575	80	25	25	40
VSPL20	20 L	650	100	25	25	40
VSPL50	50 L	840	100	40	40	100
VSPL50A	50 L	840	150	40	40	100
VSPL100	100 L	950	150	40	40	100
VSPL100A	100 L	950	225	40	40	100
VSPL200	200 L	1200	225	40	40	100
VSPL200A	200 L	1200	300	40	40	100
VSPL300	300 L	1310	300	50	50	100
VSPL300A	300 L	1310	400	50	50	100
VSPL500	500 L	1450	450	50	50	150

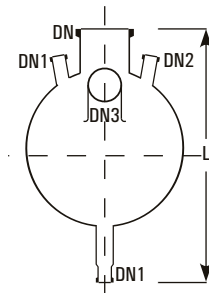

FIVE NECK BOTTOM OUTLET SPHERICAL VESSEL

Cat. Ref.	Nominal Capacity	L	DN	DN1	DN2	DN3
VSL5	5 L	425	50	25	25	40
VSL10	10 L	575	80	25	25	40
VSL20	20 L	650	100	25	25	40
VSL50*	50 L	840	100	40	40	100
VSL50A	50 L	840	150	40	40	100
VSL100*	100 L	950	150	40	40	100
VSL100A	100 L	950	225	40	40	100
VSL200*	200 L	1200	225	40	40	100
VSL200A	200 L	1200	300	50	50	100
VSL300	300 L	1310	300	50	50	100
VSL300A	300 L	1310	400	50	50	100
VSL500	500 L	1450	450	50	50	150

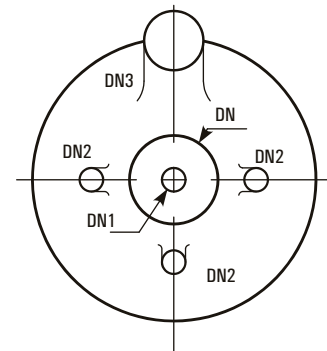

FIVE NECK BOTTOM OUTLET SPHERICAL VESSEL

Cat. Ref.	Nominal Capacity	L	DN	DN1	DN2	DN3
VS 5	5 L	425	50	25	25	40
VS 10	10 L	575	80	25	25	40
VS 20	20 L	650	100	25	25	40
VS 50*	50 L	840	100	40	40	100
VS 50A	50 L	840	150	40	40	100
VS 100*	100 L	950	150	40	40	100
VS 100A	100 L	950	225	40	40	100
VS 200*	200 L	1200	225	40	40	100
VS 200A	200 L	1200	300	40	40	100
VS 300	300 L	1310	300	50	50	100
VS 300A	300 L	1310	400	50	50	100
VS 500	500 L	1450	450	50	50	150

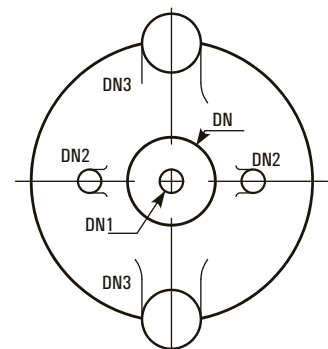

* marked items are available fast.

SPHERICAL VESSELS WITH NOZZLE AT 90°

These vessels are used in Circulatory Boiler System and are to be supported on a vessel holder. More nozzles can be provided on the equator on request for special requirements.

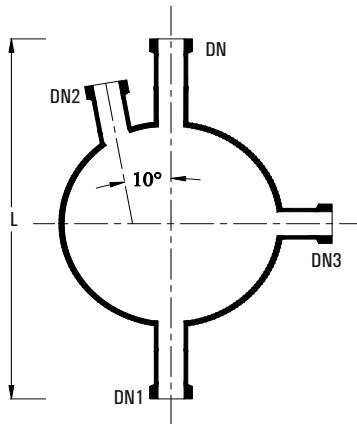

Cat. Ref.	Nominal Capacity	L	DN	DN1	DN2	DN3
VSD5	5 L	425	50	25	25	40
VSD10	10 L	500	80	25	25	40
VSD20	20 L	575	100	25	25	40
VSD50	50 L	765	100	40	40	100
VSD50A	50 L	765	150	40	40	100
VSD100	100 L	875	150	40	40	100
VSD100A	100 L	875	225	40	40	100
VSD200	200 L	1125	225	40	40	100
VSD200A	200 L	1125	300	40	40	100
VSD300	300 L	1235	300	50	50	100
VSD300A	300 L	1235	400	50	50	100
VSD500	500 L	1375	450	50	50	150

SPHERICAL RECEIVERS

Receivers are provided with builtin Dip Pipe. These are to be supported on a vessel holding ring.

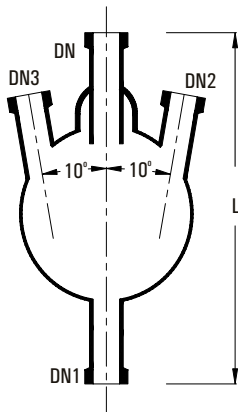

Cat. Ref.	Nominal Capacity	L	DN	DN1	(100) DN2	(100) DN3
VR5*	5 L	350	25	25	25	
VR10*	10 L	425	25	25	25	
VR20*	20 L	500	25	25	25	
VR50	50 L	675	40	25	25	
VRB5*	5 L	350	25	25	25	25
VRB10*	10 L	425	25	25	25	25
VRB20*	20 L	500	25	25	25	25
VRB50	50 L	675	40	25	25	25

ADDITION VESSELS

These vessels are provided with a short bottom outlet. These should be supported on a vessel holder/ holding ring.

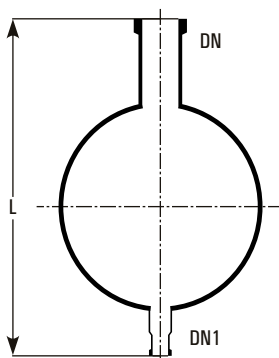

Cat. Ref.	Nominal Capacity	L	DN	DN1
VA5	5 L	375	50	25
VA10	10 L	450	80	25
VA20	20 L	525	100	25
VA50	50 L	715	100	40
VA50A	50 L	715	150	40
VA100	100 L	875	150	40
VA100A	100 L	875	225	40
VA200	200 L	1125	225	40
VA200A	200 L	1125	300	40
VA300	300 L	1235	300	50
VA300A	300 L	1235	400	50
VA500	500 L	1375	450	50

* marked items are available fast.

VESSELS

SPHERICAL VESSELS WITH WIDE BOTTOM OUTLET

These vessels are generally used to fit immersion exchangers in the bottom. Special heating mantle or bath should be used if used with.

Cat. Ref.	Nominal Capacity	L	DN	DN1	DN2	DN3
VSR50	50 L	790	100	150	40	100
VSR50A	50 L	790	150	150	40	100
VSR100	100 L	900	150	150	40	100
VRS100A	100 L	900	225	150	40	100
VSR200	200 L	1150	225	150	40	100
VSR200A	200 L	1150	300	150	40	100
VSE50	50 L	840	100	100	40	100
VSE50A	50 L	840	150	150	40	100
VSE100	100 L	950	150	150	40	100
VSE100A	100 L	950	225	225	40	100
VSE200	200 L	1200	225	225	40	100
VSE200A	200 L	1200	300	300	40	100

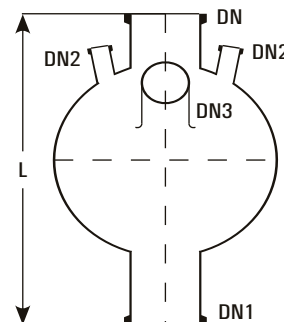

VESSELS WITH BOTTOM OUTLET VALVE SEAT

To fit a bottom outlet valve (BAL type) all spherical and cylindrical vessels can be supplied with valve seat in bottom outlet. For this, Add a suffix "/B" to the catalogue reference of a vessel, for e.g. 'VSL50' should be mentioned as 'VSL50/B'.

Notes on use of Spherical vessels.

- Generally, the centre nozzle, referred as DN in all types of vessels, is used for either stirrer fixing or if stirrer is not fixed, for vapour outlet.
- The bottom outlet, referred as DN1 in all types is used for drain. However, in type VSR & VSE, it is also used for fixing immersion heat exchanger.
- The small side nozzles, referred as DN2 in all types, are used
 - to fix thermometer pocket or,
 - to fix dip pipe for liquid inlet or,
 - to fix sparger for gas purging or,
 - to fix vacuum control or vent valve or,
 - for solid addition.
- The bigger side nozzle, referred as DN3, is used for vapour outlet where stirrer is fixed on centre neck. It can also be used for cleaning in case centre neck is used for vapour outlet.
- Vessels having long bottom outlet, viz VSM, VSPL, VSL, VS etc, can be supported in a heating mantle or heating bath. However, vessels having short bottom outlet, viz VSD, VR, VA etc. are to be supported on a vessel holder only. In case of vessels upto 20L size, vessel holding rings can be used instead of vessel holder.

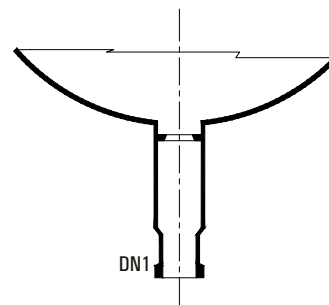

CYLINDRICAL VESSELS

Cylindrical vessels of 50 Litres and above must be supported in a vessel holder.

Cat. Ref.	Nominal Capacity	DN	DN1	L	L1
VZ5/4	5 L	100	25	850	175
VZ10/6	10 L	150	25	775	175
VZ20/9	20 L	225	25	750	175
VZ20/12	20 L	300	40	575	175
VZ50/12	50 L	300	40	1000	175
VZ50/16	50 L	400	40	710	175
VZ100/16	50 L	400	40	1050	175
VZ100/18	100 L	450	40	900	175
VZ150/16	150 L	400	40	1450	175
VZ150/18	150 L	450	40	1225	175
VZ200/18	200 L	450	40	1500	175
VZ300/24	300 L	600	50	1340	175

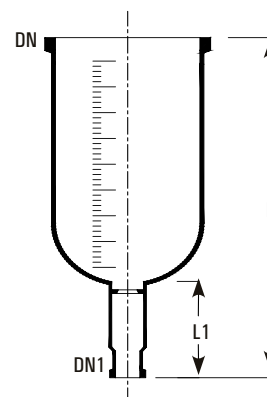

Note : For graduation required on vessel, additional charges will be applicable.

CYLINDRICAL VESSEL COVERS

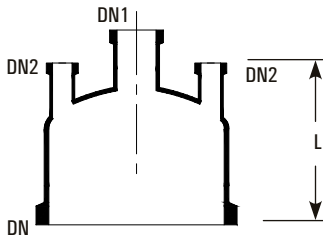

Cat. Ref.	DN	DN1	DN2	L
VZA4	100	40	2x25	200
VZA6	150	40	2x40	200
VZA9	225	50	3x25	250
VZA12	300	80	3x40	250
VZA16	400	100	3x40	275
VZA18	450	100	4x40	275
VZA24	600	100	4x40	300

KETTLES

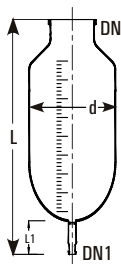

Kettles are similar to cylindrical vessels but having a reduced top neck.

Cat. Ref.	Nominal Capacity	DN	DN1	L	L1	d
KZ200	200 L	300	40	1400	175	540
KZ350	350 L	400	50	1500	175	620

Note : For graduation required on kettles, additional charges will be applicable.

JACKETED VESSELS

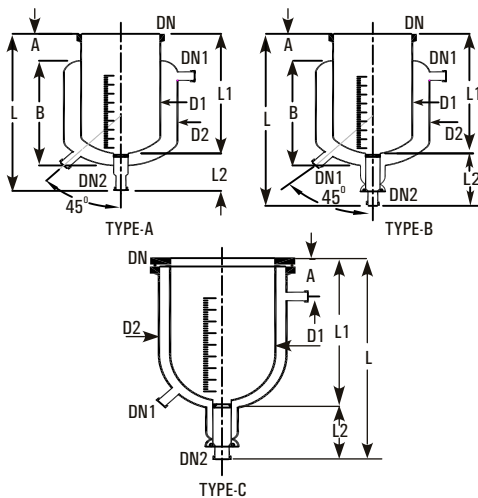

For special applications, cylindrical vessels can be supplied with a jacket for heating or cooling. Jacket is sealed to the vessel with Viton 'O' ring and other sealing compositions. The seal prevents high stresses between vessel and jacket by allowing the movement flexibility between two due to thermal expansion.

Glass Jackets

Glass Jacket can be used for a maximum operating pressure of 0.5 bar and a maximum operating temperature of 130°C in jacket. The temperature difference between jacket & vessel should not be exceed than 120°C

Cat. Ref.	L	L1	L2	A	B	D1	D2	DN	DN1	DN2	TYPE
VZD5/6	500	325	125	75	275	165	215	150	25	25	A
VZD10/9	575	400	125	90	340	230	280	225	25	25	B
VZD20/12	625	450	125	100	385	315	370	300	25	40	B
VZD30/12	750	575	175	100	510	315	370	300	25	40	B
VZD50/12/14	1050	875	175	-	-	315	365	300	25	40	C
VZD50/16/20	825	650	175	-	-	415	500	400	25	40	C
VZD100/20/24	955	780	175	-	-	516	600	500	25	40	C
VZD200/24/28	1175	1000	175	-	-	615	700	600	25	40	C

JACKETED VESSELS (TRIPLE WALL)

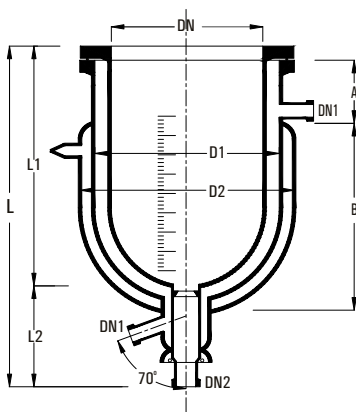

SSGPL is presenting Flexi (Detachable) "Transparent Double Jacketed Vessel" to maintain the leading position in industry by way of developing indigenously newer products with higher value towards their Mission and to cater the customer via innovation.

Salient Features

- Made from SCHOTT DURAN
- Vacuum Jacket ensures
 - Transparent insulation.
 - Minimum heat loss
 - Process visibility.
 - Minimize frost formation for cryogenics operation.
- Vacuum Jacket & main vessels are detachable ensures
 - Ease of cleaning.
 - No breakages due to thermal expansion.
 - Partial Replacement of any part can be possible to reduce the maintenance cost.

Cat. Ref.	L	L1	L2	A	B	D1	D2	DN	DN1	DN2
VZT5/6/8	620	350	175	75	310	215	275	150	25	25
VZT10/9/12	700	420	175	90	370	315	390	225	25	25
VZT20/12/14	675	500	175	125	368	365	423	300	25	40
VZT50/16/18	825	650	175	200	350	465	523	400	25	40

VESSELS

DIP PIPES

Dip pipes are used as liquid inlet for spherical vessels.

Cat. Ref.	For Vessel	DN	DN1	d	L
DP20/1*	20 L	25	25	12	300
DP50/1.5*	50 L	40	25	19	400
DP100/1.5*	100 L	40	25	19	500
DP200/1.5*	200 L	40	25	19	600

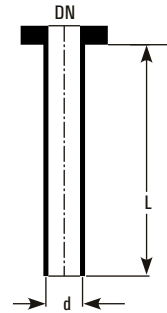

SHORT DIP PIPES

Short dip pipes are used as re-entry tubes for vessels, heat exchangers etc.

Cat.Ref.	DN	DN1	d	L	L1
DP1/1	25	25	12	100	100
DP1.5/1	40	25	19	100	100
DP1.5/1.5	40	40	19	100	100
DP2/1	50	25	25	100	100
DP2/1.5	50	40	25	100	100
DP3/1.5	80	40	37	100	125
DP4/1	100	25	25	100	150
DP4/2	100	50	50	100	150

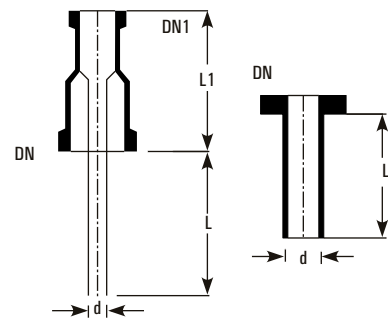

GAS SPARGERS

Gas spargers are used for gas feed/sparging in the vessels.

Cat.Ref.	For Vessel	DN	DN1	d	L	No.of Holes
SPG20/1	20 L	25	25	12	300	5x1mm
SPG50/1.5	50 L	40	25	19	400	5x1mm
SPG100/1.5	100 L	40	25	19	500	5x1mm
SPG200/1.5	200 L	40	25	19	600	5x1mm

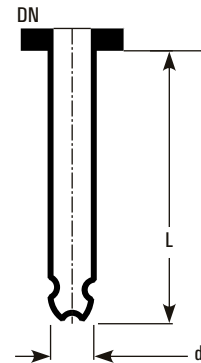

THERMOMETER POCKETS

Cat. Ref.	For Vessel	DN	d	L
TP20/1*	20 L	25	12	300
TP50/1.5*	50 L	40	19	400
TP100/1.5*	100 L	40	19	500
TP200/1.5*	200 L	40	19	600

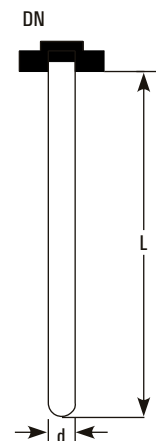

HEATING MANTLES

Heating Mantle is used for electrical heating of cylindrical as well as spherical vessels.

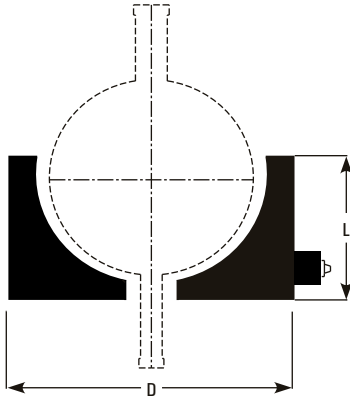

Cat.Ref.	Vessel Size	D	L	Watts	Circuits	Supply Volts
JMD5	5 L	320	190	600	1	230
JMD10	10 L	380	220	1000	2	230
JMD20	20 L	485	285	1800	3	230
JMD50	50 L	600	345	3600	3	415
JMD100	100 L	790	470	5400	3	415
JMD200	200 L	920	530	8100	3	415

HEATING BATHS

Heating baths are used for electrical or steam heating of glass vessels. Depending upon the temperature requirements, different types of thermic fluids or water can be used as heating media. Heating baths are provided with a pair of encased heaters with controller box, a coil for passing the steam or cooling water, a cushioned vessel holding ring, a bottom outlet sealing arrangement, a lid and threaded socket type inlets and outlets.

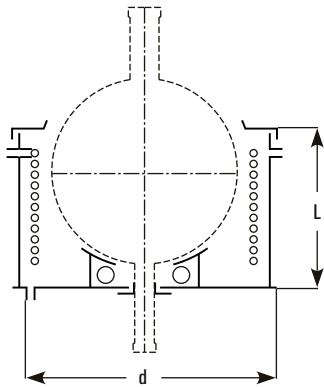

Cat.Ref.	Vessel Size	d	L	Watts	HTA Vessel	HTA Coils
SBH20	20 L	480	340	2x2000	0.25	0.4
SBH50	50 L	615	415	2x3000	0.5	0.6
SBH100	100 L	720	535	2x4500	0.7	1
SBH200	200 L	900	620	2x6000	1	1.5
SBH300	300 L	1150	735	3x6000	1.85	2.5
SBH500	500 L	1385	880	4x6000	2.5	4.0

COOLING BATHS

Cooling baths are used for cooling the glass vessel with ice crystals. Cooling Baths are provided with a vessel holding ring, bottom outlet sealing arrangement and a lid.

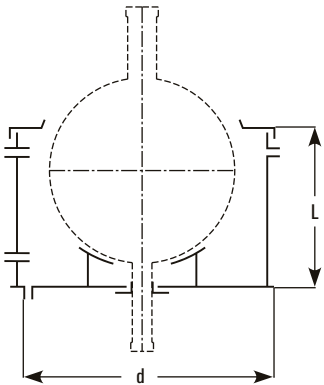

Cat.Ref.	Vessel Size	d	L
BHC20	20 L	480	340
BHC50	50 L	615	415
BHC100	100 L	720	535
BHC200	200 L	900	620

VESSEL HOLDERS

Vessel holders are made of cast aluminum with a plaster lining shaped to fit the vessel. These are to be supported on 3 jacking bolts.

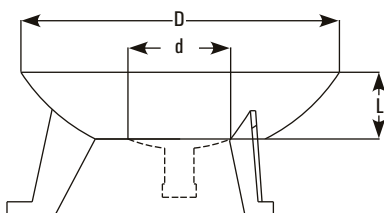

Cat.Ref.	Vessel Size	D	d	L
VSS10*	10 L	265	160	90
VSS20*	20 L	325	230	100
VSS50*	50 L	390	230	100
VSS100*	100 L	410	250	100
VSS200	200 L	700	400	215

* marked items are available fast.

VESSELS

VESSEL HOLDING RINGS

These metal rings are wrapped with asbestos rope and are to be supported on two jacking bolts.

Cat.Ref.	Vessel Size	d	L
VRS2	2 L	100	15
VRS5*	5 L	150	15
VRS10*	10 L	215	15
VRS20*	20 L	310	15

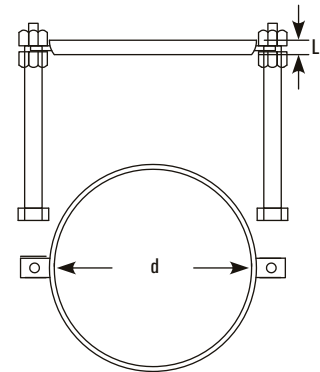

DECANTORS

Decantation is a process of separation of two immiscible liquids having different densities. When these liquids allowed to settle forms two distinct layers, heavier at bottom and lighter at top. SSGPL has developed a Decantor which is suitable for continuous decantation.

The mixture of liquids is continuously fed in the Decantor at low velocity. This allow sufficient residence time for the formation of separate layers. The light phase liquid is continuously removed from the light phase outlet at the top. The heavy phase liquid enters the dip pipe at lower end and overflow in the discharge pipe and is removed from the bottom.

SSGPL Decantor provides continuous separation, visual monitoring, and ensure separation even after feed is stopped.

Decantors can be provided with Adjustable overflow valve, (Type B) to adjust the position of interface for different operating situations.

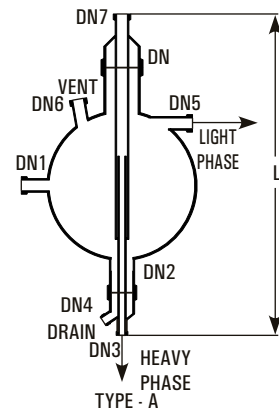

Cat. Ref.	Nominal Capacity	L	DN	Inlet DN1	DN2	Heavy Phase Outlet DN3	Drain DN4	Light Phase Outlet DN5	Vent DN6	DN7	Type
SPS20	20 L	800	80	25	50	25	25	25	25	50	A
SPS50	50 L	1025	100	40	50	25	25	40	40	50	A
SPS100	100 L	1175	150	40	50	25	25	40	40	50	A
SPS200	200 L	1475	225	40	50	25	25	40	40	50	A
SPA20	20 L	1000	80	25	50	25	25	25	25	50	B
SPA50	50 L	1225	100	40	50	25	25	40	40	80	B
SPA100	100 L	1375	150	40	50	25	25	40	40	80	B
SPA200	200 L	1675	225	40	50	25	25	40	40	80	B

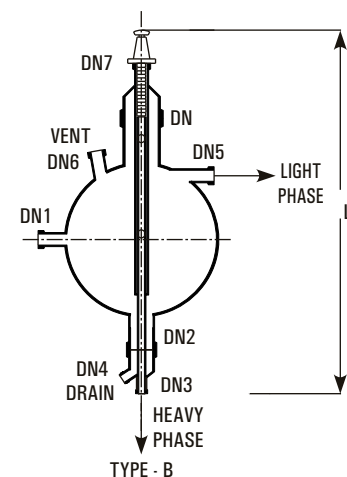

Decantors can also be constructed with horizontal cylindrical vessels (Cat.ref. HPS or HPA) to provide larger separating surface.

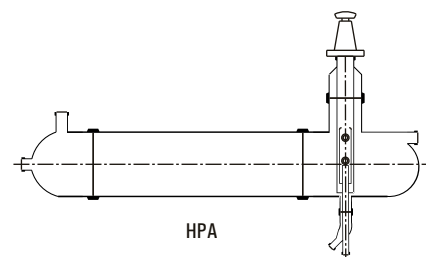
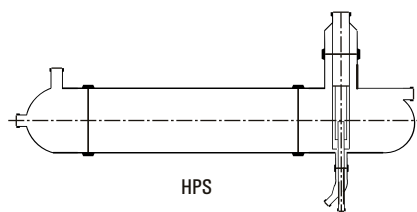

STIRRERS



A variety of stirrer & stirrer drives are available to use glass vessels as agitated reaction equipment.

1. Stirrer material of construction: Glass, Stainless Steel or PTFE Lined.
2. Stirrer Design: Impeller stirrer with blades, Vortex stirrer, Propeller Stirrer & anchor Stirrer.
3. Stirring Drive: Non-flameproof or Flameproof stirrer drive, 192 RPM with Variable Frequency Drive.
4. Stirring Assembly: Stirring Assembly with bellow seal or with mechanical seal.

STIRRERS

Stirrers are assembled in a vessel using a chuck, seal & a reducer. A typical arrangement of stirrer fitted in a vessel is shown in the diagram.

Size	A	B	C	D	L
20 L	250	150	450	25	825
50 L	300	200	600	50	1050
100 L	300	250	700	50	1200
200 L	300	300	900	50	1450
300L	300	25	1000	50	1275

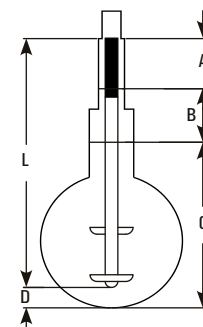

CHUCK & SEAL

This unit is suitable for use under corrosive conditions. Only glass and PTFE are exposed to process fluids. Bellow seal can be used under vacuum down to 10mm Hg absolute. Mechanical seal can be use under vacuum 1mm Hg absolute or under pressure permitted into glass vessels. Generally a reducer is require to connect the chuck and seal to top neck of the vessel

Cat.Ref. Bellow Seal	Cat.Ref. Mechanical Seal	Vessel	DN	L	L1	d
CSA1*	CSM1*	20 L	50	300	250	25
CSA1.5*	CSM1.5*	50,100, 200 L	80	360	300	47

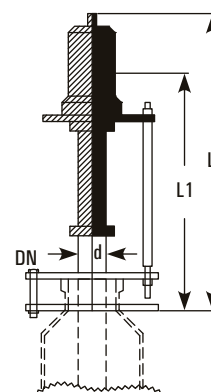

STIRRER WITH TEFLON BLADES

These stirrers are used with liquid of low viscosity.

Cat.Ref.	Vessel	L	L1	L2	L3	d	D
STB10	10	600	300	15	175	25	100
STB20	20	825	300	25	200	25	100
STB50*	50	1050	300	25	200	47	150
STB100*	100	1200	300	30	250	47	175
STB200*	200	1450	300	30	325	47	200
STB300	300	1550	350	30	425	59	275

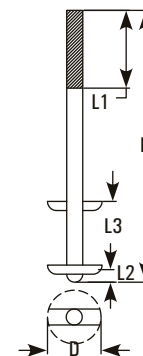

VORTEX STIRRER

These stirrers are used with liquid of low viscosity containing small solid particles.

Cat.Ref.	Vessel	L	L1	L2	d	D
STV50	50	1050	300	50	47	95
STV100	100	1200	300	65	47	140
STV200	200	1450	300	65	47	190

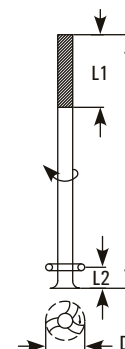

PROPELLER STIRRER

These stirrers are used with liquid of high viscosity or liquid with big solid particles.

Cat.Ref.	Vessel	L	L1	L2	d	D
STP50	50	1050	300	50	47	95
STP100	100	1200	300	65	47	145
STP200	200	1450	300	65	47	210

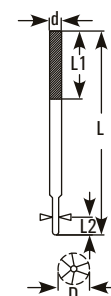

* marked items are available fast.

STIRRERS

FLAMEPROOF STIRRER DRIVES

A 1400 RPM 3 Phase flameproof motor coupled with reduction gear is supplied along with a flexible shaft. Motor is mounted on a metal base frame, which is designed to install easily with a Glass Assembly.

Cat.Ref.	HP	RPM
FSD 0.5*	0.5	192
FSD 1	1	192



VARIABLE FREQUENCY DRIVE (VFD)

3 Phase Non-Flameproof and Flameproof VFD Type are available to control the speed of stirrer drives, 50-192 RPM, Speed controller.

Cat.Ref.	Phase	Type
VFD 0.5*	3	VFD



EXPLOSION PROOF PANEL

3 Phase explosion proof panel are also available.



EXPLOSION PROOF STIRRER DRIVE

We also offer Ex certified motor coupled with bonfiglioli gearbox for better safety and performance.

Cat.Ref.	HP	RPM
FSD 0.5/ Ex	0.5	192



* marked items are available fast.

HEAT EXCHANGERS



The overall heat transfer co-efficient of Borosilicate glass equipment is comparatively favourable with many alternative materials because of its smooth surface which improves the thermal coefficient & reduce the tendency of fouling.

Heat Exchangers are available in 2 basic designs:

1. Conventional Coil Type Condensers.
2. Shell & Tube Type.

HEAT EXCHANGERS

SHELL AND TUBE HEAT EXCHANGERS

INTRODUCTION

Shell & tube heat exchangers offer large surface area in combination with efficient heat transfer and compactness. These are widely used in industries for various duties like cooling, heating, condensation, evaporation etc. SSGPL are the pioneers in the field of glass shell and tube heat exchangers in India and their product has a wide market acceptability.

SALIENT FEATURES

1. Universal corrosion resistance an excellent alternative to expensive MOCs like graphite, hastelloy, copper titanium, tantalum and other exotic metals.
2. Excellent heat transfer as fouling does not occur on smooth glass surfaces.
3. Flexibility of installation vertical / horizontal.
4. Easy replacement of tubes for repair and cleaning.
5. Available in wide range of HTAs.
6. Ease of installation due to light weight.
7. Economical.
8. Suitable for applications where large HTAs are required in limited space.

ADVANTAGES OVER CONVENTIONAL COIL TYPE HEAT EXCHANGERS

- (1) The overall heat transfer coefficient in shell and tube heat exchanger is about 3 times higher than in coil type heat exchanger.
- (2) The pressure drop in shell and tube heat exchanger is minimal compared to 2-3 kg/cm² in coil side of coil type heat exchanger.
- (3) For requirement of higher heat transfer areas shell and tube heat exchanger is the only alternative.

CONSTRUCTION FEATURES

The glass tubes are sealed individually into PTFE tube sheet with special PTFE sockets and packing. This unique ferrule type sealing arrangement permits easy replacement and cleaning of tubes. Baffles on shell side ensure improved heat transfer by increased turbulence. Further details of construction can be seen in the diagram.

- Made from SCHOTT DURAN.
- Joint less tubes offer better pressure rating.

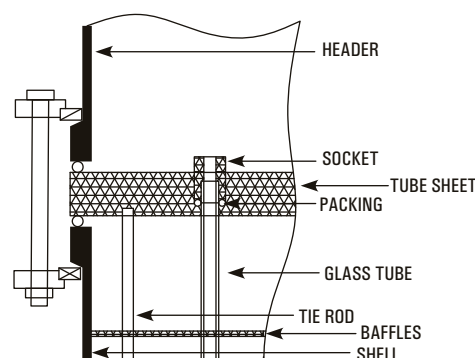

TYPE

Three basic versions * are available :

Material Of Construction				
Model	Shell	Tube	Header	Duty
RGG	Glass	Glass	Glass	For heat transfer between two aggressive media.
RGM	Glass	Glass	Steel/ FRP	For heat transfer between aggressive media in shell & non-aggressive media in tubes.
RMG	Steel/FRP	Glass	Glass	For heat transfer between aggressive media in tubes & non-aggressive media in shell.

* SSGPL provides assistance to clients for selecting the right model for specific duty.

HEAT EXCHANGERS

DIMENSIONAL SPECIFICATIONS

Cat. Ref. RGG/RMG	6/3	6/4	6/5	6/6	9/6	9/8	9/10	9/12	12/12	12/16	12/21	12/25	16/21	16/25
Area (m ²)	3	4	5	6	6	8	10	12	12	16	21	25	21	25
DN	150				225				300				400	
DN1	80				100				150				225	
DN2	50				80				80				100	
DN3	25				40				40				50	
DN4	50				50				50				80	
H1	175				250				300				450	
H2	150				200				250				300	
L	2500	3100	3700	4300	2620	3220	3820	4520	2550	3150	3950	4550	3100	3500
L1	1900	2500	3100	3700	1900	2500	3100	3800	1800	2400	3200	3800	2000	2400
L2	150	150	150	150	225	225	225	225	225	225	225	225	400	400
L3	1600	2200	2800	3400	1450	2050	2650	3350	1350	1950	2750	3350	1200	1600
L4	250	250	250	250	300	300	300	300	300	300	300	300	550	550
L5	125	125	125	125	175	175	175	175	175	175	175	175	225	225
L6	1980	2580	3180	3780	2000	2600	3200	3900	1930	2530	3330	3930	2185	2585
T	50				60				75				100	
No. of Tubes	37				73				151				241	
No. of Baffles	11	15	19	23	7	9	13	17	5	7	9	11	5	7

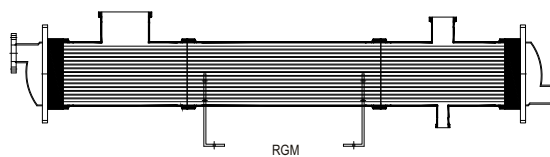
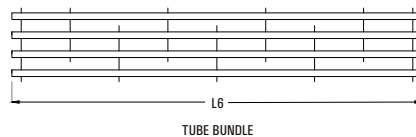
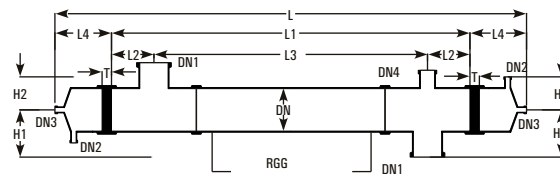

RANGE OF APPLICATIONS

Permissible temperature range for both shell & tube sides - 40°C to 150°C.

Maximum permissible temperature difference between shell & tube sides 120°C.

All sizes & models are suitable for full vacuum on both side. Maximum limiting pressures are tabulated here below :

Model	Side	Maximum Permissible Pressure Range, Kg/cm ² (g)		
		150 DN	225 DN	300 DN
RGG	Shell-Glass	2.0	1.0	1.0
	Tube-Glass	2.0	1.0	1.0
	Dome-Glass			
RGM	Shell-Glass	2.0	1.0	1.0
	Tube-Glass	3.5	3.5	3.5
	Dome-Metal			
RMG	Shell-Metal	3.5	3.5	3.5
	Tube-Glass	2.0	1.0	1.0
	Dome-Glass			

The above ranges of application are admissible limiting values. For each specific case SSGPL recommends the admissible operating data based on the relations between pressure and temperature, size and model.

HEAT EXCHANGERS

PERFORMANCE & DESIGN DATA

The particular advantage of shell & tube heat exchanger is high heat transfer performance. The relation between heat transfer and velocity of flow can be easily seen in the diagram. On receipt of the operating data from client the most favourable shell and tube heat exchanger is selected. This accurate design combined with most reliable quality assurance ensure economy and operational reliability for the user. For approximate sizing some typical heat transfer coefficients are given here below :

Media	use	U-Values	
		kcal/m ² hr k	W/m ² k300
Steam water	Condensation	350-550	410-640
Water-Water	Cooling	250-350	290-410
Water-air	Cooling	30-60	35-70

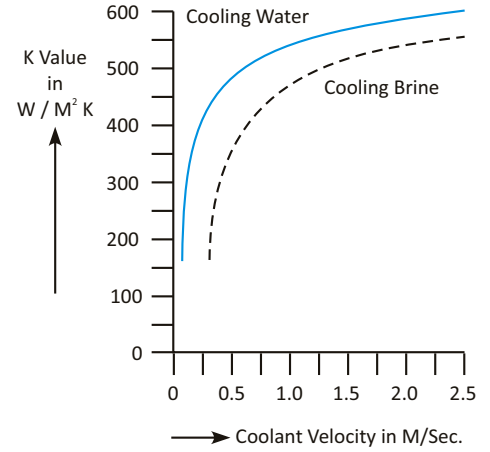

HEAT EXCHANGERS

CONDENSERS

Condensers are used for condensation of vapours and cooling of liquids. Condensers are made by fusing number of parallel coils in a glass shell. Coils are made in different diameters using tubes of different bores.

The average co-efficient of heat transfer in coil condenser is considered as-
 Condensation 200 - 270 Kcal/m²,hr,°C appx.
 Cooling 100 - 150 Kcal/m²,hr,°C appx.

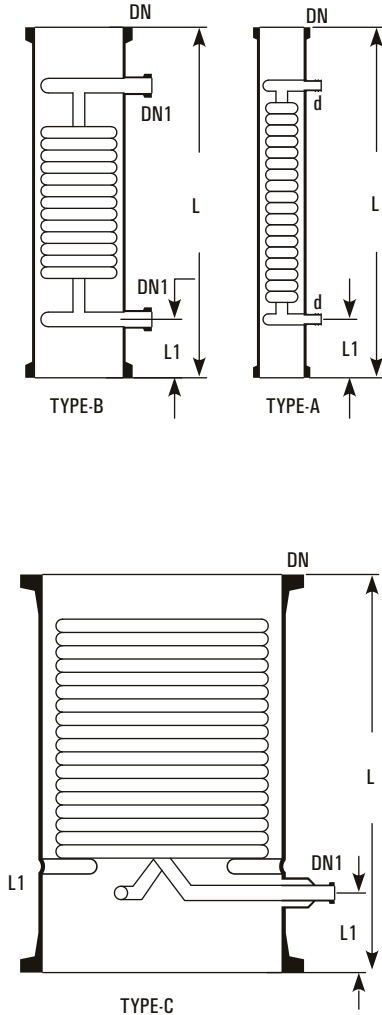

Cat. Ref.	DN	d/ DN1	L	L1	Type	Actual H.T.A. m ²	Cross Area Cm ²	Free Coolant Rate Kg/hr.	Max. Jacket Cap. Litre
HE3/3.5*	80	16	600	75	A	0.35	5	1300	2
HE4/5*	100	19	600	75	A	0.50	30	2400	4
HE4/6*	100	19	750	100	A	0.60	30	2400	6
HE6/10	150	25	600	100	B	1.00	52	2600	9
HE6/15*	150	25	850	100	B	1.50	52	2600	11
HE9/25*	225	25	800	110	B	2.50	125	3300	18
HE12/25	300	25	600	125	B	2.50	175	5700	25
HE12/40*	300	25	900	125	B	4.00	175	5700	35
HE16/40	400	25	600	125	B	4.00	450	6200	60
HE16/50	400	25	700	125	B	5.00	450	6200	70
HE18/60	450	40	750	150	C	6.00	820	4800	100
HE18/80	450	40	900	150	C	8.00	820	6200	110
HE24/120	600	50	1250	300	C	12.00	1520	6200	265

Precautions to be taken in use of condensers

- Vapours should be passed through shell only.
- Maximum pressure of coolant should be 2.7 bars.
- Adequate flow of coolant should be used.
- Steam should not be used in coils.
- Coolant should not be heated to boiling point.
- Coolant control valve should be turned slowly.
- Coolant should be allowed to drain freely.
- Brine can be used in coils in a closed circuit.
- Water main should be connected with flexible hose.
- Ensure no freezing of water remaining in the coils.
- Condensers should be mounted vertically only.
- Condensers can be mounted in series to provide larger surface area.

METHODS OF USE

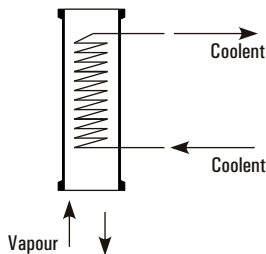

Vapours from bottom

This method is simple to install over a reactor. However this results in condensate returning substantially at its condensing temperature. In this method care must be taken that condensate is not excessive that it can lead to "logging" the coils and create back pressure in the system. Generally a reflux divider is used below the condenser to take out the distillate.

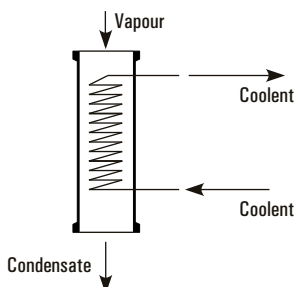

Vapours from top

This method produce a cool condensate using the entire cooling surface area. This method should be used where the condensate can lead to "logging" of coils.

* marked items are available fast.

HEAT EXCHANGERS

BOILERS

Boilers are used for vaporization of liquids by passing the steam in the coils. Boilers are made by fusing number of parallel coils in a glass shell. In Boilers, coils are designed to provide bigger cross section in the shell side as compared to condensers. The average heat transfer in Boilers is considered as 350 Kcal/m²,hr,°C at a steam pressure of 3.5 bar.

Cat. Ref.	DN	DN1	DN2	L	L1	Type	Actual H.T.A. m ²	Free Cross Area Cm ²	Jacket Cap. Litre
HEB4	100	25	25	375	100	A	0.15	40	2
HEB4/4	100	100	25	400	100	B	0.15	40	3
HEB6	150	40	25	450	100	A	0.35	50	5
HEB6/6	150	150	25	500	100	B	0.35	50	7
HEB9	225	40	25	700	100	A	1.00	150	16
HEB9/9	225	225	25	700	100	B	1.00	180	20
HEB12/12	300	300	25	700	125	B	1.30	330	40

Notes on use of Boilers :

- Steam should be passed in the coils at a maximum pressure of 3.5 bar which is equivalent to a temperature of 147°C.
- For higher temperature (maximum upto 200°C) heat transfer fluids can be passed in the coils. - Cold liquids
- Cold liquids should be preheated for better results.
- Boilers should be mounted in an external circulatory loop (as shown in figure) and not direct at the bottom of flask or column
- Under certain circumstances, boilers can be mounted in series to provide larger heat transfer area.

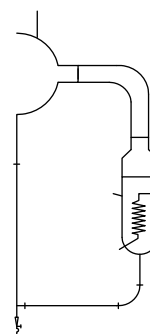
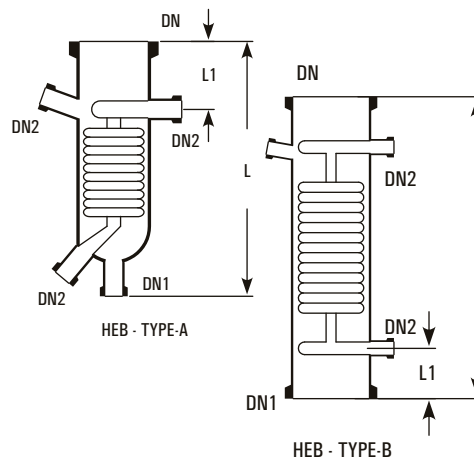

ANGLED HOSE CONNECTOR ASSEMBLIES

Metal / Plastic angled hose connector assemblies are available to connect the flexible hose to the condensers. These are provided with a mating flange, a rubber gasket and nut bolts.

Cat.Ref.	DN	d	L
PMC1	25	22	70

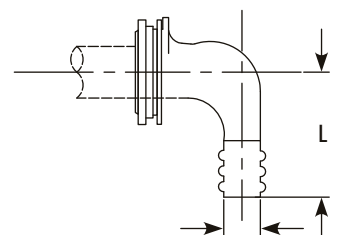

IMMERSIONS

Immersion heat exchangers are used to control exothermic reaction in glass vessels. They can be used with vessels having wider bottom outlet (type VSR and VSE). These are provided with a central hole through the coil battery so that a special, extended type, stirrer can be fitted which extends to the bottom of heat exchanger and provide through action.

In most applications, cooling water is used in coils (max. pressure 2.7 bar g.), but they can also be used with steam (max. pressure 3.5 bar g.). In latter case the coils must be completely immersed in liquid. Immersions are not recommended for use with products which have a tendency to crystallise.

Cat. Ref.	DN	DN1	DN2	L	L1	L2	d	Actual H.T.A. m ²
HEM6	150	40	25	200	200	75	145	0.4
HEM9	225	40	25	300	200	75	200	0.6

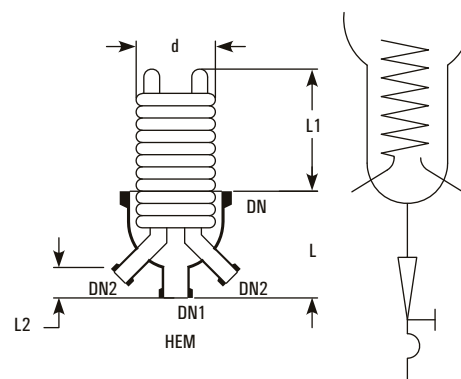

HEAT EXCHANGERS

PRODUCT COOLERS

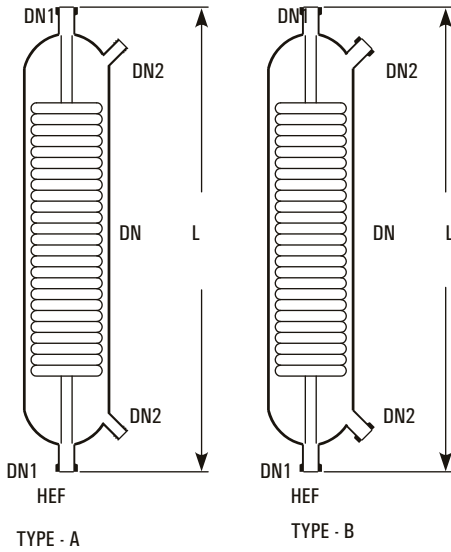

Product coolers are used for cooling of liquids, typically, for the cooling of distillates from the distillation columns.

Unlike coil condensers, in product coolers, product travels through the coil battery and coolant through shell. This provides more resident time to the product to be cooled. For direct connection with distillate lines, all the product coolers are provided with 25 DN connections.

Cat.Ref.	DN	DN1	DN2	L	Actual HTA m ²	Type
HEF1/1*	50	25	12	450	0.1	A
HEF1/2*	50	25	12	600	0.2	A
HEF1/3.5*	80	25	16	600	0.35	A
HEF1/5*	100	25	19	600	0.5	A
HEF1/10	150	25	25	600	0.7	B
HEF1/15	150	25	25	850	1.25	B

UTILITY CONNECTION FOR CONDENSER

When installing coil type heat exchangers appropriate precautions should be taken. The main points to be taken into account when planning to use these items as coolers are (See also flow chart below).

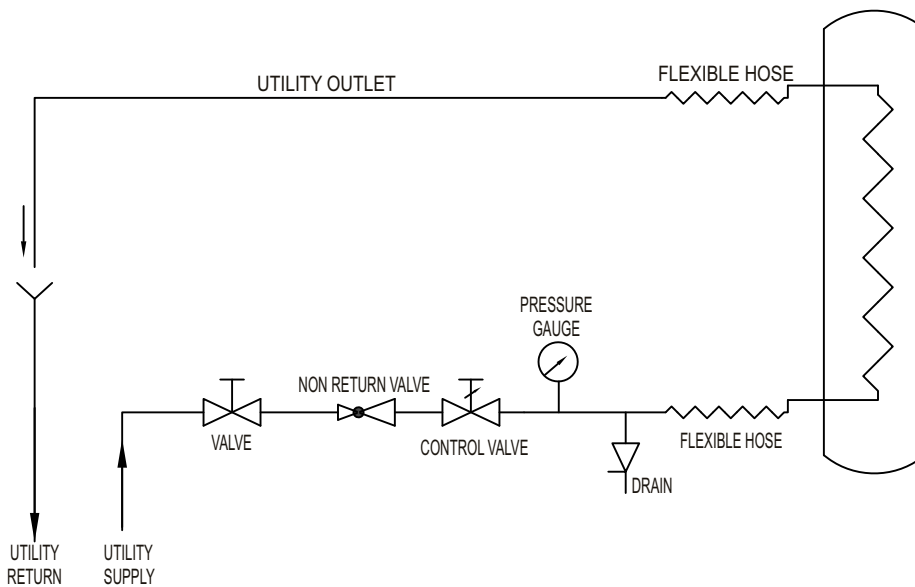

COLUMN COMPONENTS



In many operations like reaction, extraction & absorption, the transparency of glass is particular advantage. For such process a range of column components are available in Borosilicate glass which offers many advantages like:

1. Inert to almost all chemicals hence no risk of contamination.
2. Transparency allows visual monitoring of the process flow patterns, colour changes etc.
3. Almost universal resistance to corrosion.
4. Smooth surface permits easy cleaning & prevents fouling.

COLUMN COMPONENTS

COLUMN SECTIONS

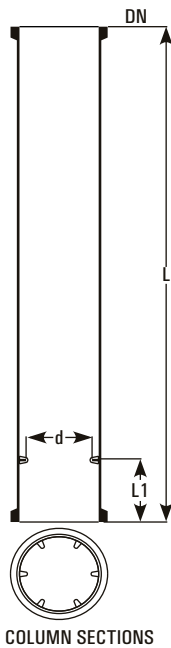

Column can be constructed either by using pipe sections with support plates or using column sections with packing supports.

Column sections are provided with fused shelf where packing support can rest.

Cat.Ref.	DN	L	L1	Minimum packing Size	Usual packing Size
CS3/1000	80	1000	75	9	12
CS4/1000	100	1000	75	12	15
CS6/1000	150	1000	75	15	25
CS6/1500	150	1500	75	15	25
CS9/1000	225	1000	100	20	25
CS9/1500	225	1500	100	20	25
CS12/1000	300	1000	100	25	25
CS12/1500	300	1500	100	25	25
CS16/1000	400	1000	150	25	25
CS16/1500	400	1500	150	25	25
CS18/1000	450	1000	150	25	25
CS18/1500	450	1500	150	25	25
CS24/1000	600	1000	200	40	40

COLUMN SECTIONS WITH THERMOMETER BRANCH

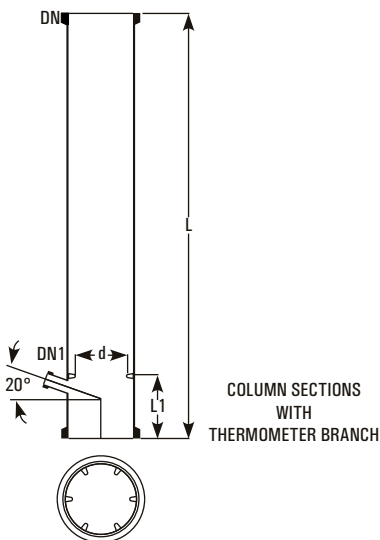

Above column sections can be provided with a thermometer branch below the packing shelf at 20° slope

Cat.Ref.	DN	DN1	L	L1	d
CST3/1000	80	25	1000	125	50
CST4/1000	100	25	1000	125	75
CST6/1000	150	25	1000	125	125
CST6/1500	150	25	1500	125	125
CST9/1000	225	25	1000	150	175
CST9/1500	225	25	1500	150	175
CST12/1000	300	25	1000	150	250
CST12/1500	300	25	1500	150	250
CST16/1000	400	25	1000	200	250
CST16/1500	400	25	1500	200	350
CST18/1000	450	25	1000	200	400
CST18/1500	450	25	1500	200	400
CST24/1000	600	25	1000	250	540

COLUMN COMPONENTS

PACKING SUPPORTS

Packing supports Type A are made of fused glass rods. Packing supports Type B (heavy duty) are made of PTFE Blocks with holes.

Cat.Ref. Size	DN	L	Cross Section Area	Max. Load Kgs.	Minimum Packing	Type
CP3*	80	10	45%	10	12	A
CP4*	100	12	50%	15	15	A
CP6*	150	15	55%	30	25	A
CP9*	225	19	60%	50	25	A
CP12*	300	19	65%	75	25	A
HD16	400	70	70%	150	25	B
HD18	450	70	70%	200	25	B
HD24	600	95	70%	300	40	B
HDP16	400	45-50	57%	100	25	C
HDP18	450	45-50	54%	100	25	C
HDP24	600	45-50	58%	150	40	C

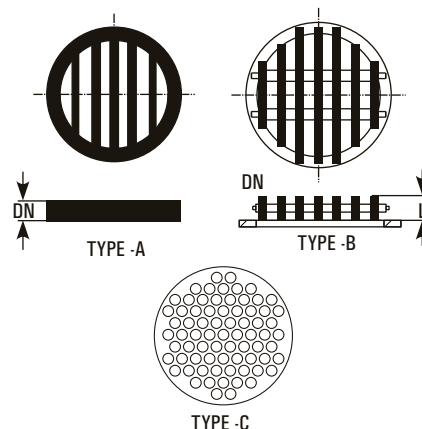

PTFE PERFORATED PLATES

These are used as packing retainers to prevent the packing from lifting due to vapour velocity. These can be clamped between two components without using any gasket.

Cat.Ref.	DN	d	L
TCP3	80	99	7
TCP4	100	132	9
TCP6	150	184	10
TCP9	225	254	12
TCP12	300	340	16
TCP16	400	463	25
TCP18	450	525	25
TCP24	600	689	30

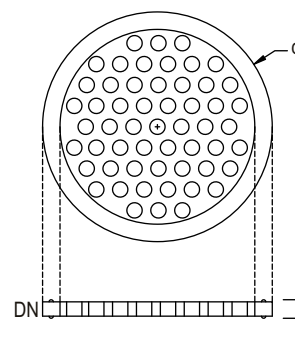

Packings require for various pipe sections (Kgs.)

Pipe Section	Packing size						
	Vol (L)	FCB	FCB 12	FCB 15	FCB 25	FCB 40	FCB 50
PS3/1000	5	3	3	2	-	-	-
PS4/1000	8	-	4	3	3	-	-
PS6/1000	18	-	9	7	7	-	-
PS9/1000	37	-	-	15	15	15	-
PS12/1000	66	-	-	17	30	25	-
PS16/1000	125	-	-	-	65	50	53
PS18/1000	165	-	-	-	90	65	70
PS24/1000	295	-	-	-	-	115	125

Notes of use of Column Packing

- Due to their low bulk densities, Glass Raschig rings are particularly suitable for packing glass columns.
- Generally, the ratio of Column diameter to packing diameter should not be less than 8:1.
- When using smaller packing size, a small layer of larger packing should be used on packing support, to prevent the smaller packing falling through.
- In vacuum application and applications involving high vapour velocities, packing may be lifted and may damage to other parts. To prevent this, a packing retainer (PTFE perforated plates) should be used above the packed section.

COLUMN COMPONENTS

COLUMN PACKING-RASCHIG RINGS

Raschig ring ranging from 8 mm to 50 mm are available in 3.3. Borosilicate glass.



Cat. Ref.	Size	Bulk Density Kg/Ltr	Specific Surface m ² /m ³	Glass
FCB8	8x8	0.66	633	Borosilicate
FCB10	10x10	0.52	487	Borosilicate
FCB12	12x12	0.48	425	Borosilicate
FCB15	15x15	0.43	330	Borosilicate
FCB20	20x20	0.30	300	Borosilicate
FCB25	25x25	0.28	240	Borosilicate
FCB30	30x30	0.27	180	Borosilicate
FCB40	40x40	0.22	160	Borosilicate
FCB50	50x50	0.19	120	Borosilicate

PALL RINGS

Pall Rings are also available for column packing as per below specification.

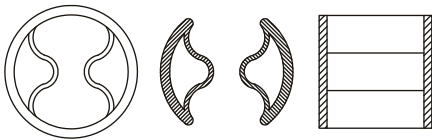

Cat.Ref.	Size	Bulk Density Kg/Ltr	Specific Surface m ² /m ³	Glass
FCP30	30x30	0.38	234	Borosilicate
FCP40	40x40	0.32	187	Borosilicate
FCP50	50x50	0.26	140	Borosilicate

COLUMN FEED PIPE

Feed pipe directs the process fluid to the centre of the column.

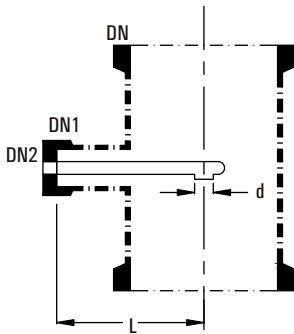

Cat.Ref.	DN	DN1	DN2	L	d
FP3	80	25	25	100	12
FP4	100	25	25	125	12
FP6	150	40	25	150	19
FP9	225	40	25	175	19
FP12	300	40	25	225	19
FP16	400	40	25	275	19
FP18	450	40	25	300	19
FP24	600	50	40	450	25

DN refers the nominal diameter of the column.

COLUMN FEED SPARGERS

In column feed spargers, holes are provided at three sides of pipe.

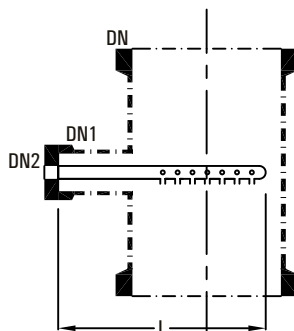

Cat.Ref.	DN	DN1	DN2	L	Holes
SPG3	80	25	25	125	21x2mm
SPG4	100	25	25	150	21x2mm
SPG6	150	40	25	200	27x2mm
SPG9	225	40	25	275	27x2mm
SPG12	300	40	25	350	30x3mm
SPG16	400	40	25	450	39x3mm
SPG18	450	40	25	500	39x3mm
SPG24	600	50	40	650	60x3mm

DN refers the nominal diameter of the column.

COLUMN COMPONENTS

SPRAY FEED SECTION

Spray feed section are provided with circular tube having holes at the bottom.

Cat.Ref.	DN	DN1	L	L1	Holes
FR3	80	25	200	100	21x2mm
FR4	100	25	250	125	21x2mm
FR6	150	40	250	125	27x2mm
FR9	225	40	250	125	27x2mm
FR12	300	40	300	150	30x3mm

For bigger columns, Spray feed pipe with Unequal Tee should be used.

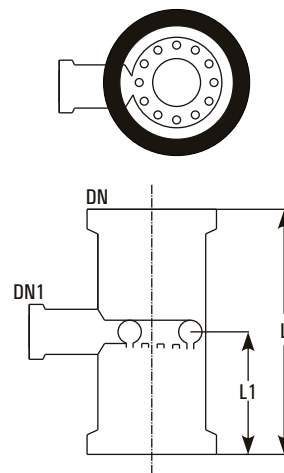

SPRAY FEED PIPES

Spray feed pipes are provided with oval tube having holes at the bottom. These should be used with unequal tees.

Cat.Ref.	DN	DN1	DN2	L	L1	Holes Size	Tee Suitable
FD6	150	80	25	225	125	27x2mm	PTU6/3
FD9	225	100	25	325	150	27x2mm	PTU9/4
FD12	300	150	25	400	200	30x3mm	PTU12/6
FD16	400	150	50	500	200	39x3mm	PTU16/6
FD18	450	150	50	550	200	39x3mm	PTU18/6
FD24	600	150	50	700	200	60x3mm	PTU24/6

DN refers the nominal diameter of the column.

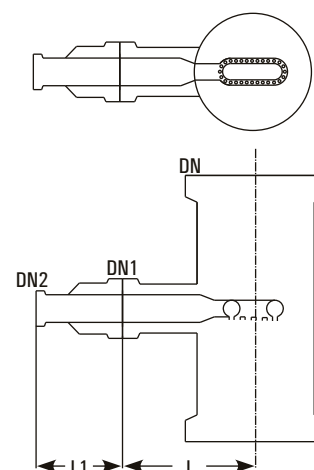

PTFE REDISTRIBUTORS

PTFE redistributors are used to prevent channeling in columns. These can be clamped between two components without using any gasket.

Cat.Ref.	DN	d	L
TL3	80	55	20
TL4	100	80	20
TL6	150	100	20
TL9	225	175	22
TL12	300	215	25
TL16	400	315	25
TL18	450	365	30
TL24	600	420	30

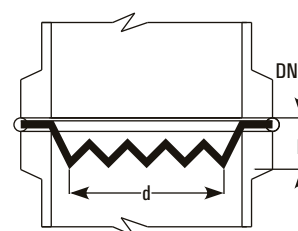

COLUMN COMPONENTS

COLUMN ADAPTORS

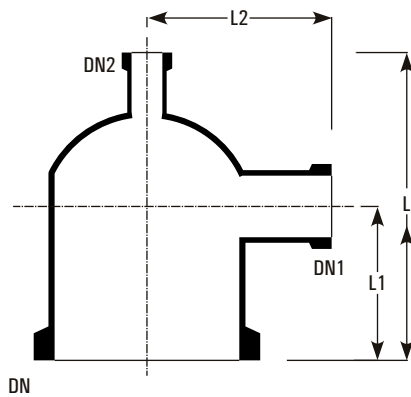

Cat.Ref.	DN	DN1	DN2	L	L1	L2
CA3/1/1	80	25	25	150	75	100
CA3/1.5/1	80	40	25	175	100	100
CA3/2/1	80	50	25	175	100	100
CA4/1/1	100	25	25	150	75	125
CA4/1.5/1	100	40	25	175	100	125
CA4/2/1	100	50	25	225	125	125
CA4/3/1	100	80	25	225	125	125
CA6/1/1	150	25	25	200	100	150
CA6/1.5/1	150	40	25	200	100	150
CA6/2/1	150	50	25	250	125	150
CA6/3/1	150	80	25	250	150	150
CA6/4/1	150	100	25	275	150	175
CA9/1.5/1.5	225	40	40	250	150	175
CA9/2/1.5	225	50	40	250	150	175
CA9/3/1.5	225	80	40	300	175	200
CA9/4/1.5	225	100	40	350	175	200
CA9/6/1.5	225	150	40	400	200	250
CA12/1.5/1.5	300	40	40	300	150	225
CA12/2/1.5	300	50	40	300	150	225
CA12/3/1.5	300	80	40	300	150	250
CA12/4/1.5	300	100	40	350	175	250
CA12/6/1.5	300	150	40	425	225	250
CA12/9/1.5	300	225	40	450	225	300
CA16/2/2	400	50	50	400	200	300
CA16/3/2	400	80	50	450	250	300
CA16/4/2	400	100	50	450	250	300
CA16/6/2	400	150	50	550	300	350
CA16/9/2	400	225	50	550	300	350
CA18/2/2	450	50	50	400	200	325
CA18/3/2	450	80	50	450	250	350
CA18/4/2	450	100	50	450	250	350
CA18/6/2	450	150	50	550	300	350
CA18/9/2	450	225	50	550	300	400
CA18/12/2	450	300	50	750	400	400
CA24/2/2	600	50	50	450	200	400
CA24/3/2	600	80	50	500	250	400
CA24/4/2	600	100	50	500	250	400
CA24/6/2	600	150	50	650	300	450
CA24/9/2	600	225	50	650	300	450
CA24/12/2	600	300	50	800	400	500

Column adaptors with DN2 of different size (maximum equaling to DN1) can be manufactured with the same dimensions.

* marked items are available fast.

COLUMN COMPONENTS

FLAT TOP COLUMN ADAPTORS

These are generally used as headers of shell and tube heat exchangers and columns.

Cat.Ref.	DN	DN1	L	L1
CA3/1	80	25	100	75
CA3/1.5	80	40	125	100
CA4/1	100	25	100	75
CA4/1.5	100	40	125	100
CA6/1	150	25	150	100
CA6/1.5	150	40	150	100
CA6/2	150	50	200	125
CA6/3	150	80	200	150
CA9/1.5	225	40	200	150
CA9/2	225	50	200	150
CA9/3	225	80	250	175
CA9/4	225	100	250	175
CA12/2	300	50	250	150
CA12/3	300	80	250	150
CA12/4	300	100	300	175
CA12/6	300	150	350	225

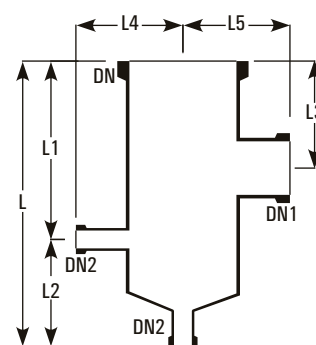
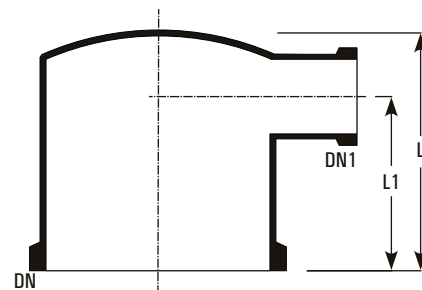

Cat.Ref.	DN	DN1	DN2	L	L1	L2	L3	L4	L5
CAM4/2/1/1	100	50	25	450	300	150	200	125	125
CAM6/3/1/1	150	80	25	450	300	150	200	150	150
CAM9/3/1/1	225	80	25	450	300	150	200	175	200
CAM12/3/1/1	300	80	25	450	300	150	200	225	250

REFLUX DIVIDERS

Manually Operated

Reflux dividers are used to take off the distillate from the column. Usually a valve is to be fitted on distillate outlet which controls the reflux coarsely.

Cat.Ref.	DN	DN1	DN2	L	L1	Free Corss Section Cm2	Max. Product L/hr
RDA3*	80	25	25	200	100	20	300
RDA4*	100	25	25	250	150	50	500
RDA6*	150	25	25	250	150	100	700
RDA9*	225	25	25	375	150	150	900
RDA12*	300	25	25	375	150	250	1100
RDA16	400	40	40	500	200	350	1300
RDA18	450	40	40	600	275	500	1500

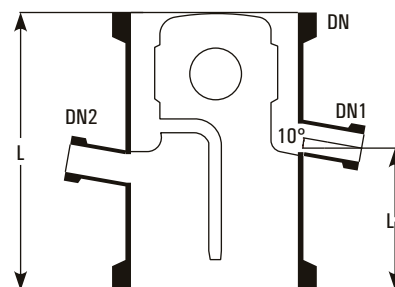

DN2 is used for insertion of a thermometer pocket. A bellow is recommended on the distillate outlet DN1.

COLUMN COMPONENTS

Magnetically Operated

These reflux dividers are to be used with an electro-magnet and a timer. These have a swinging funnel mechanism which is operated magnetically from outside to remove the condensate or to return the reflux. Through this, correct control of reflux-ratio is possible. Funnel remains at 100% reflux position while magnet is inactive.

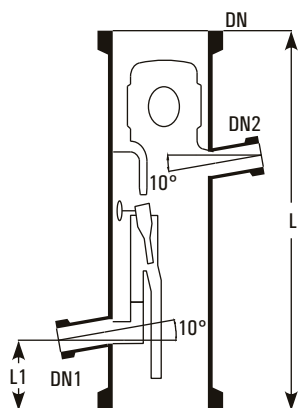

Cat.Ref.	DN	DN1	DN2	L	L1	Free Corss Section Cm2	Max. Product L/hr
RHM3	80	25	25	375	75	20	90
RHM4	100	25	25	400	75	50	180
RHM6	150	25	25	450	100	100	300
RHM9	225	25	25	550	100	150	500
RHM12	300	25	25	700	100	250	650
RHM16	400	40	40	800	150	350	1000
RHM18	450	40	40	900	150	500	1300

DN2 is used for insertion of a Thermometer Pocket. A liquid seal is recommended on the distillate outlet of this reflux divider to prevent the vapour passing directly to the receiver.

PNEUMATIC REFLUX DIVIDER

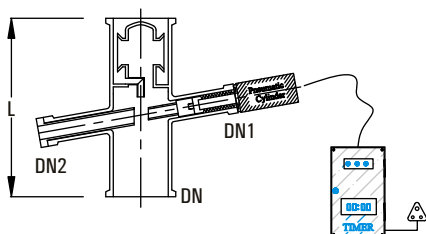

Cat.Ref.	DN	DN1	DN2	L
RPH3	80	25	25	250
RPH4	100	25	25	250
RPH6	150	40	25	250
RPH9	225	40	50	375
RPH12	300	40	50	375

THERMOMETER POCKETS FOR REFLUX DIVIDER

These thermometer pockets are to be used with reflux dividers or column sections. DN refers to the nominal diameter of the Reflux divider or Column.

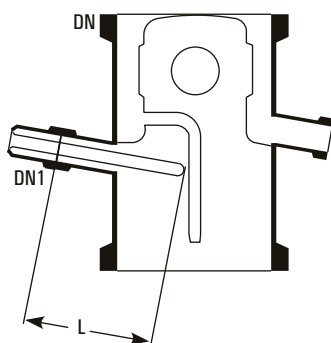

Cat.Ref.	DN	DN1	d	L
TP3*	80	25	12	75
TP4*	100	25	12	100
TP6*	150	25	12	125
TP9*	225	25	12	150
TP12*	300	25	12	200
TP16	400	40	19	250
TP18	450	40	19	300

COLUMN COMPONENTS

LIQUID SEALS

Liquid seals are to be fitted on the distillate outlet of magnetically operated reflux divider. This prevents the passing of vapour directly to the receiver.

Cat.Ref.	DN	DN1	L	Type
LS1*	25	25	200	A
LS1.5	40	25	300	A
LSV1	25	-	200	B

* marked items are available fast.

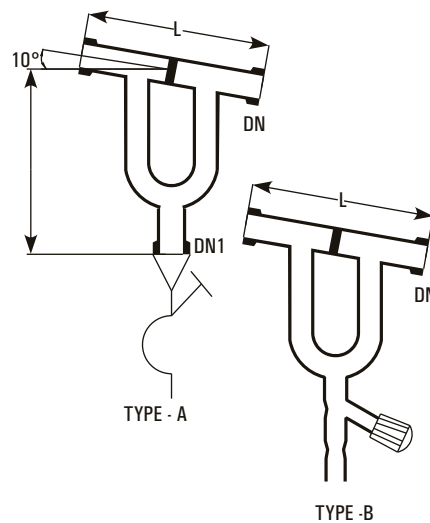

COLUMN SECTION WITH INBUILT PACKING SUPPORT

Introduce single piece column section with inbuilt packing support.

Advantages of this column against conventional column section:

- Ease in installation being a single piece instead of two pieces.
- There is no need to maintain stock of CS and packing support.
- Increases effective packed height which results in to increase in efficiency.
- Zero maintenance against column flooding.

Cat.Ref.	DN	D	d	L	Max Load Kgs	Suitable Packing Size
CSP3/1000	80	10	10	1000	20	12
CSP4/1000*	100	10	14	1000	30	15
CSP6/1000*	150	12	22	1000	60	25
CSP9/1000*	225	12	22	1000	90	25
CSP12/1000*	300	12	22	1000	150	25

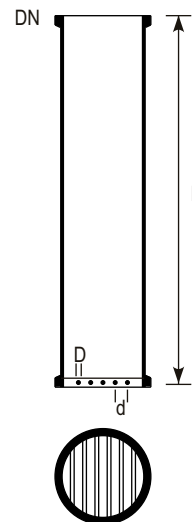

MEASUREMENT AND CONTROL

DIGITAL TEMPERATURE INDICATOR

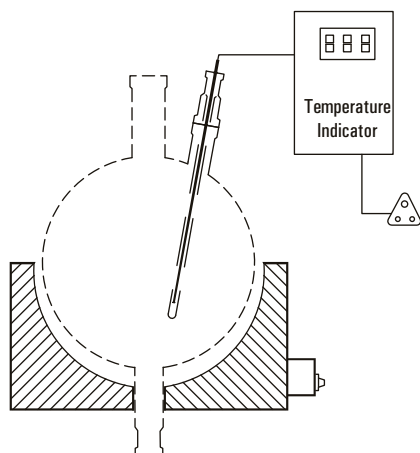

These are generally used as headers of shell and tube heat exchangers and columns.

This instrument is mainly used to monitor the temperature of liquid in a glass vessel in a typical Glass Distillation Unit.

The instrument consists of a Temperature indicator and a Resistance Temperature Detectors (RTD). The instrument works on 230V, 50Hz power supply. This displays the temperature in degree Centigrades in three and half digits of 12.5mm character height.

Cat.Ref.	Vessel size	RTD Length
DTI20	20	400
DTI50	50	500
DTI100	100	600
DTI200	200	700

ELECTRO-MAGNETS

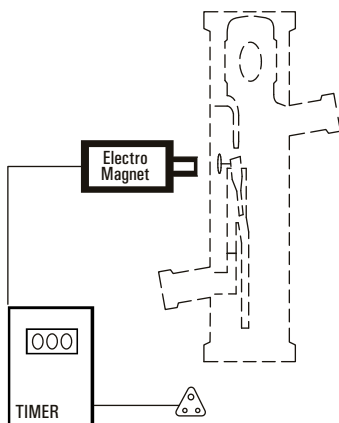

Electro - magnets are used to operate Magnetically operated Reflux dividers. When 'On' the magnet attracts the swinging funnel of the reflux divider so that distillate can be taken off.

Electro-magnets are to be mounted outside the glass column, just near to the reflux divider, with the help of adjustable fittings. These are designed to use with Timers to maintain correct ratio between 'Off' and 'On' timings of its activation.

Electro-magnets work on 220V DC power supply, for which an output socket is provided in the Timers.

Cat. Ref.	Type
RPM	Non-flameproof
RPF	Flameproof

TIMERS

Timers are designed to use with Electro-magnets to provide a correct ratio of reflux and distillate when operating a Magnetically operated reflux divider.

Timers work on a power supply of 230V, 50Hz.

Cat. Ref.	Type
QRT	Flameproof

COUPLINGS AND GASKETS

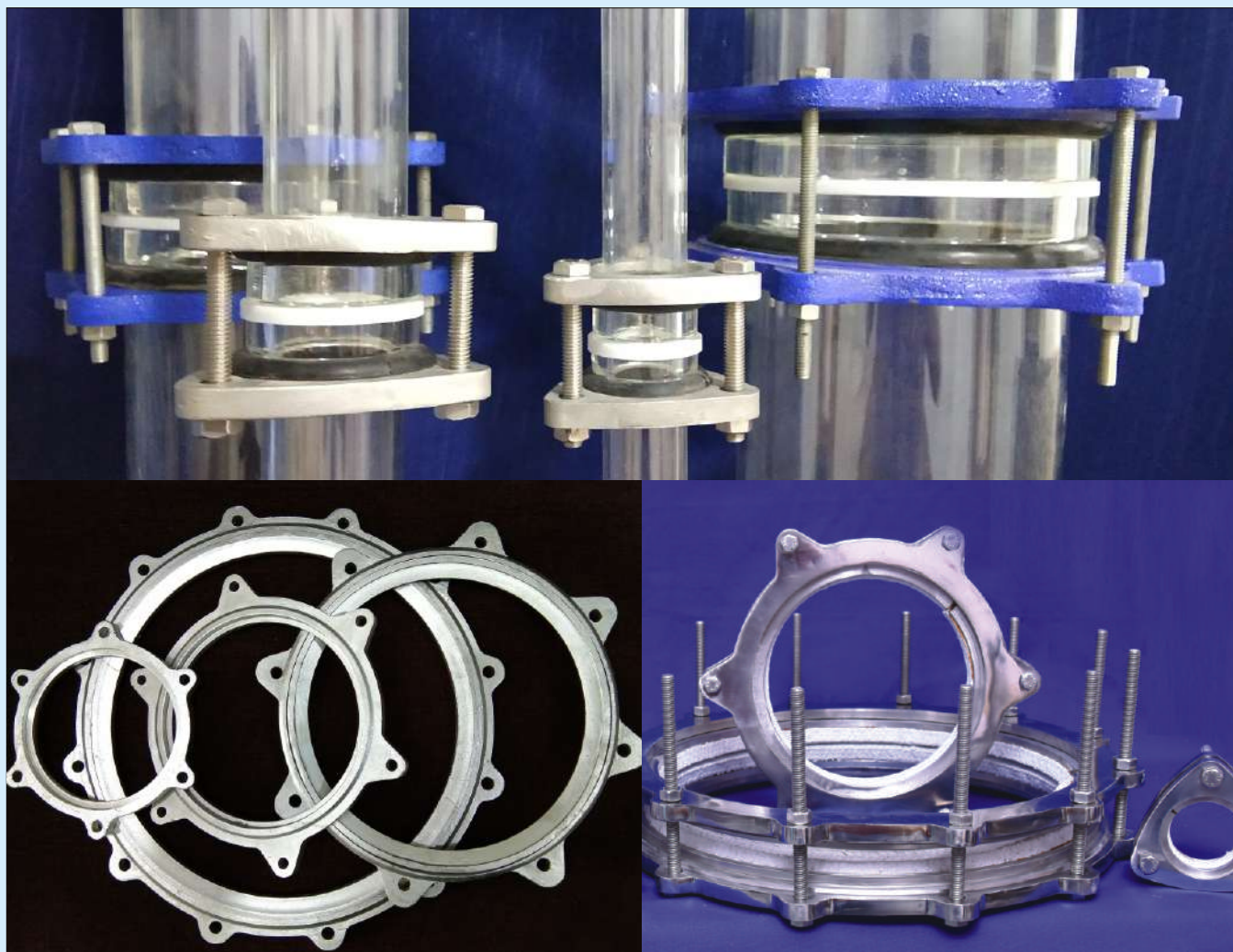

The couplings used with glass equipment are important from two main points of view:

1. They must ensure the effective seal of the joint.
2. They should not induce any undue stress in the glass.
3. They must be reliable in all service conditions.

In this section we have covered coupling to join glass components together as well as to join glass components with a other metal equipment.

PTFE bellows are available for normal & vacuum applications, together with flanges to connect them to glass or non-glass equipment.

COMPLETE COUPLINGS

A complete coupling is a set of two backing flanges with insert and nut-bolts. Complete set of flanges require to make a joint & standard one are available in Cast Iron & Mild Steel. Also available in other MOC like Stainless Steel 304 & 316, Siliumin, Bakelite.

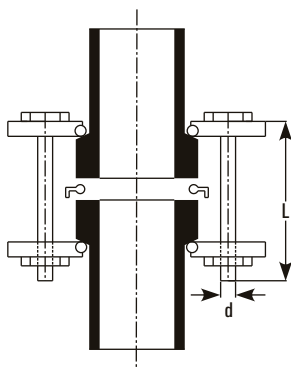

Cat.Ref.	DN	Flanges		inserts		Nuts-Bolts		
		Cat.Ref.	Qty	Cat.Ref.	Qty	d	L	Qty
CT0.5	12	CF0.5	2nos	CN0.5	2nos	1/4"	50	3nos
CT0.7	15	CF0.7	2nos	CN0.7	2nos	1/4"	50	3nos
CT1*	25	CF1	2nos	CN1	2nos	5/16"	65	3nos
CT1.5*	40	CF1.5	2nos	CN1.5	2nos	5/16"	65	3nos
CT2*	50	CF2	2nos	CN2	2nos	5/16"	75	3nos
CT3*	80	CF3	2nos	CN3	2nos	5/16"	75	6nos
CT4*	100	CF4	2nos	CN4	2nos	5/16"	100	6nos
CT6*	150	CF6	2nos	CN6	2nos	5/16"	100	6nos
CT8	200	CF8	2nos	CN8	2nos	3/8"	125	8nos
CT9*	225	CF9	2nos	CN9	2nos	3/8"	125	8nos
CT12*	300	CF12	2nos	CN12	2nos	3/8"	150	12nos
CF with inbuilt insert above size of 12								
CT16	400	CF16	2nos			3/8"	150	12nos
CT18*	450	CF18	2nos			1/2"	150	12nos
CT24	600	CF24	2nos			1/2"	150	12nos
CT28	700	CF28	2nos			1/2"	150	12nos
CT32	800	CF32	2nos			1/2"	150	24nos

QUICK RELEASE COUPLINGS

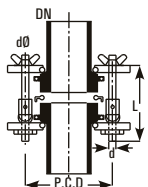

Cat.Ref.	DN	PCD	nxdØ
QCT3	80	133	6x9Ø
QCT4	100	178	6x9Ø
QCT6	150	254	6x9Ø
QCT9	225	310	8x11Ø
QCT12	300	395	12x11Ø

For easy & fast opening or closing of couplings as quick as possible without using tools, the Quick Release Coupling is an ideal solution. In case of solid charging material to reaction or addition vessels, we recommend to use our Quick Release Coupling.

Quick Release coupling are offered in cast iron & stainless steel material as per the requirement. Quick Release Coupling is available from DN 80 to DN 300 sizes.

BACKING FLANGES

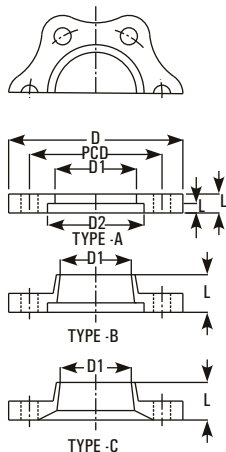

Backing flanges are used to couple a glass end to a glass end or to a bellow. Backing flanges are made of cast iron and are used with Inserts.

Cat.Ref.	DN	D	D1	D2	PCD	n x dØ	L	L1	Type
CF0.5	12	50	25	28	38	3 x 7Ø	6	3	A
CF0.7	15	65	29	37	48	3 x 7Ø	6	3.5	A
CF1	25	92	43	51	70	3 x 9Ø	10	6	A
CF1.5	40	110	58	66	86	3 x 9Ø	10	6	A
CF2	50	120	70	81	98	3 x 9Ø	12	8	A
CF3	80	155	101	112	133	6 x 9Ø	12	8	A
CF4	100	200	134	148	178	6 x 9Ø	12	8	A
CF6	150	275	186	196	254	6 x 9Ø	15	8	A
CF8	200	315	236	258	280	8 x 11Ø	14	6	A
CF9	225	350	260	282	310	8 x 11Ø	28	8	B
CF12	300	425	342	363	395	12 x 11Ø	34	8	B
CF16	400	525	467	476	495	12 x 12Ø	22	8	A
CF18	450	630	537	557	585	12 x 14Ø	37	8	B
CF24	600	755	643	690	710	12 x 14Ø	50	5	C
CF28	700	860	740	780	820	16 x 20Ø	26	6	C
CF32	800	990	861	922	950	24 x 14Ø	67	5	C

INSERTS

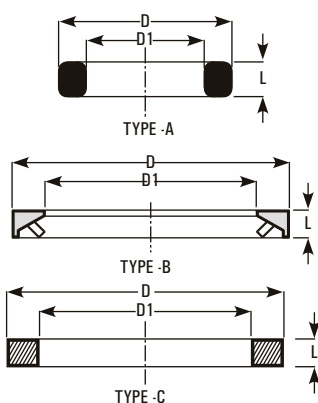

Split ring type inserts are used with backing flanges. In addition, insert made of suitable composite rubber material for 25 DN to 150 DN size. New PTFE (make Champion, Klinger) insert are being introduced for 25DN to 800DN.

Cat.Ref.	DN	D	D1	L	Type
CN0.5	12	28	20	8	A
CN0.7	15	37	22	8	A
CN1	25	50	34	10	A
CN1.5	40	65	48	10	A
CN2	50	80	61	8	B
CN3	80	111	90	9	B
CN4	100	147	119	10	B
CN6	150	195	168	10	B
CN8	200	256	216	8	B
CN9	225	280	240	10	B
CN12	300	361	324	10	B

* marked items are available fast.

COUPLINGS

ADAPTOR BACKING FLANGES

Adaptor backing flanges are used to couple a glass end to the flange having different bolt configuration. These flanges are made of cast iron and are supplied with inserts. These are particularly used to fit a glass equipment on a non-glass equipment like Glass-lined Reactor etc. Adaptor backing flanges are generally supplied undrilled. However, if specified, these can be supplied drilled as per "Table E", "Table F" and "ASA150" standards.

Drilled to Table E

Cat.Ref.	PCD	n x d ϕ
CFA0.5/E	62	4 x 7 ϕ
CFA0.7/E	62	4 x 7 ϕ
CFA1/E	82	4 x 12 ϕ
CFA1.5/E	98	4 x 12 ϕ
CFA2/E	114	4 x 16 ϕ
CFA3/E	146	4 x 16 ϕ
CFA4/E	178	8 x 16 ϕ
CFA6/E	235	8 x 19 ϕ
CFA9/E	324	12 x 19 ϕ
CFA12/E	406	12 x 23 ϕ

Undrilling flanges

Cat.Ref.	DN	D	D1	D2	L
CFA0.5	12	80	25	28	6
CFA0.7	15	85	29	37	6
CFA1	25	115	43	51	10
CFA1.5	40	150	58	66	10
CFA2	50	165	70	81	12
CFA3	80	200	101	112	12
CFA4	100	220	134	148	12
CFA6	150	285	186	196	15
CFA9	225	395	260	282	15
CFA12	300	445	342	363	18

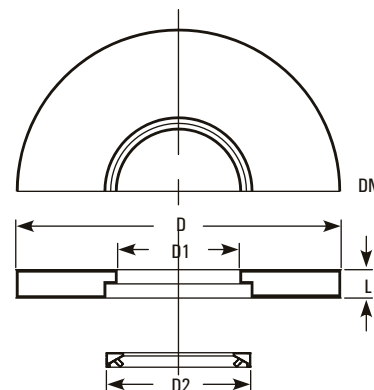

Drilled to ASA 150

Cat.Ref.	PCD	n x d ϕ
CFA0.5/A	62	4 x 7 ϕ
CFA0.7/A	62	4 x 7 ϕ
CFA1/A	79	4 x 12 ϕ
CFA1.5/A	98	4 x 12 ϕ
CFA2/A	121	4 x 16 ϕ
CFA3/A	152	4 x 16 ϕ
CFA4/A	190	8 x 16 ϕ
CFA6/A	241	8 x 19 ϕ
CFA9/A	298	8 x 19 ϕ
CFA12/A	432	12 x 23 ϕ

Drilled to Table F

Cat.Ref.	PCD	n x d ϕ
CFA0.5/F	67	4 x 7 ϕ
CFA0.7/F	67	4 x 7 ϕ
CFA1/F	87	4 x 16 ϕ
CFA1.5/F	105	4 x 16 ϕ
CFA2/F	127	4 x 16 ϕ
CFA3/F	165	8 x 16 ϕ
CFA4/F	190	8 x 16 ϕ
CFA6/F	260	12 x 19 ϕ
CFA9/F	356	12 x 23 ϕ
CFA12/F	438	16 x 23 ϕ

PTFE "O" RING WITH LOCKING COLLAR

These PTFE O rings are specially made to use as gaskets in glass fittings. These are provided with a collar which helps to locate it on the glass end correctly.

Cat.Ref.	DN	D	D1	d	L
TR0.5	12	26	18	3	5
TR0.7	15	28	17	3	5
TR1*	25	42	33	3	5
TR1.5*	40	57	48	3	5
TR2*	50	70	59	3	5
TR3*	80	100	88	3	5
TR4*	100	134	119	4	6
TR6*	150	186	168	4	6
TR8*	200	235	215	-	10
TR9*	225	260	236	4	7
TR12*	300	342	318	4	7

Above 12" TM used

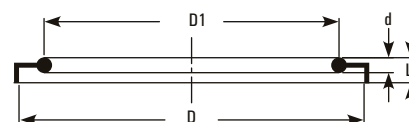

TM SIZE	OD	ID	THICKNESS
TM16	463	400	5
TM18	525	455	5
TM20	585	500	5
TM24	684	600	5
TM28	780	709	5
TM32	916	845	5

PTFE BELLOWS - GLASS TO GLASS

These bellows are used in installation of glass equipment for following purposes :
 - to provide safe branching of pipelines from the main glass equipment.
 - to accommodate odd degrees and variation in length.

Bellows are supplied along with required bellow flanges and nut-bolts. Distance-locking bolts are provided to avoid excessive compression or contraction of the bellow. Gaskets are not required where bellows are used. For drilling details, refer "Bellow flanges"

Line bellows

These can withstand a temperature of 200°C under normal atmospheric conditions.

* marked items are available fast.

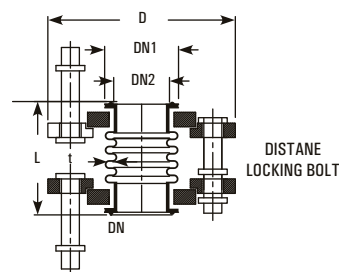

COUPLINGS

ADAPTOR BACKING FLANGES

Adaptor backing flanges are used to couple a glass end to the flange having different bolt configuration. These flanges are made of cast iron and are supplied with inserts. These are particularly used to fit a glass equipment on a non-glass equipment like Glass-lined Reactor etc. Adaptor backing flanges are generally supplied undrilled. However, if specified, these can be supplied drilled as per "Table E", "Table F" and "ASA150" standards.

Drilled to Table E

Cat.Ref.	PCD	n x d ϕ
CFA0.5/E	62	4 x 7 ϕ
CFA0.7/E	62	4 x 7 ϕ
CFA1/E	82	4 x 12 ϕ
CFA1.5/E	98	4 x 12 ϕ
CFA2/E	114	4 x 16 ϕ
CFA3/E	146	4 x 16 ϕ
CFA4/E	178	8 x 16 ϕ
CFA6/E	235	8 x 19 ϕ
CFA9/E	324	12 x 19 ϕ
CFA12/E	406	12 x 23 ϕ

Undrilling flanges

Cat.Ref.	DN	D	D1	D2	L
CFA0.5	12	80	25	28	6
CFA0.7	15	85	29	37	6
CFA1	25	115	43	51	10
CFA1.5	40	150	58	66	10
CFA2	50	165	70	81	12
CFA3	80	200	101	112	12
CFA4	100	220	134	148	12
CFA6	150	285	186	196	15
CFA9	225	395	260	282	15
CFA12	300	445	342	363	18

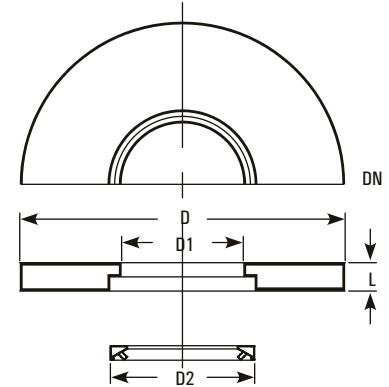

Drilled to ASA 150

Cat.Ref.	PCD	n x d ϕ
CFA0.5/A	62	4 x 7 ϕ
CFA0.7/A	62	4 x 7 ϕ
CFA1/A	79	4 x 12 ϕ
CFA1.5/A	98	4 x 12 ϕ
CFA2/A	121	4 x 16 ϕ
CFA3/A	152	4 x 16 ϕ
CFA4/A	190	8 x 16 ϕ
CFA6/A	241	8 x 19 ϕ
CFA9/A	298	8 x 19 ϕ
CFA12/A	432	12 x 23 ϕ

Drilled to Table F

Cat.Ref.	PCD	n x d ϕ
CFA0.5/F	67	4 x 7 ϕ
CFA0.7/F	67	4 x 7 ϕ
CFA1/F	87	4 x 16 ϕ
CFA1.5/F	105	4 x 16 ϕ
CFA2/F	127	4 x 16 ϕ
CFA3/F	165	8 x 16 ϕ
CFA4/F	190	8 x 16 ϕ
CFA6/F	260	12 x 19 ϕ
CFA9/F	356	12 x 23 ϕ
CFA12/F	438	16 x 23 ϕ

PTFE "O" RING WITH LOCKING COLLAR

These PTFE O rings are specially made to use as gaskets in glass fittings. These are provided with a collar which helps to locate it on the glass end correctly.

Cat.Ref.	DN	D	D1	d	L
TR0.5	12	26	18	3	5
TR0.7	15	28	17	3	5
TR1*	25	42	33	3	5
TR1.5*	40	57	48	3	5
TR2*	50	70	59	3	5
TR3*	80	100	88	3	5
TR4*	100	134	119	4	6
TR6*	150	186	168	4	6
TR8*	200	235	215	-	10
TR9*	225	260	236	4	7
TR12*	300	342	318	4	7

Above 12" TM used

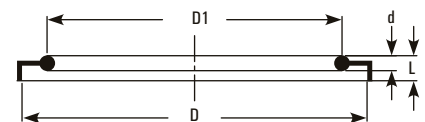

TM SIZE	OD	ID	THICKNESS
TM16	463	400	5
TM18	525	455	5
TM20	585	500	5
TM24	684	600	5
TM28	780	709	5
TM32	916	845	5

PTFE BELLOWS - GLASS TO GLASS

These bellows are used in installation of glass equipment for following purposes :
 - to provide safe branching of pipelines from the main glass equipment.
 - to accommodate odd degrees and variation in length.

Bellows are supplied along with required bellow flanges and nut-bolts. Distance-locking bolts are provided to avoid excessive compression or contraction of the bellow. Gaskets are not required where bellows are used. For drilling details, refer "Bellow flanges"

Line bellows

These can withstand a temperature of 200°C under normal atmospheric conditions.

* marked items are available fast.

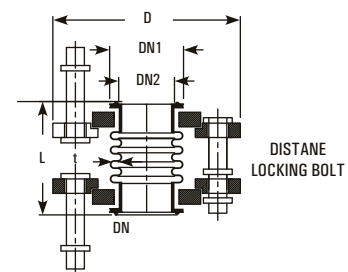

COUPLINGS

BELLOW FLANGES

Bellow flanges are used to fit a bellow to a glass component. Standard Bellow are made Cast Iron. Cast Iron with Epoxy Coated, Cast Iron with PTFE coated, Aluminum, Silumin, Stainless Steel, 304 & 316 and are used in FBV, VB, FB type bellows. These are provided with two holes at 180° for Distance - locking bolts and are supplied with a split ring.

Cat.Ref.	DN	D	D1	D2	D3	L	L1	L2
BF0.5	12	50	25	28	20	6	3	6
BF0.7	15	65	29	37	22	6	3	6
BF1*	25	95	43	51	33	7	3	6
BF1.5*	40	110	58	66	45	7	3	6
BF2*	50	120	70	81	57	7	3	6
BF3*	80	155	101	112	84	7	3	6
BF4*	100	200	134	148	113	8	3	6
BF6*	150	275	186	196	164	8	3	6
BF9*	225	350	260	282	234	8	3	6
BF12	300	425	342	363	310	10	5	8

Drilling details

Cat.Ref.	PCD	n x d ϕ	n x d1 ϕ
BF0.5	38	3 x 9 ϕ	2 x 9 ϕ
BF0.7	48	3 x 9 ϕ	2 x 9 ϕ
BF1	70	3 x 9 ϕ	2 x 9 ϕ
BF1.5	86	3 x 9 ϕ	2 x 9 ϕ
BF2	98	3 x 9 ϕ	2 x 9 ϕ
BF3	133	6 x 9 ϕ	2 x 9 ϕ
BF4	178	6 x 9 ϕ	2 x 9 ϕ
BF6	254	6 x 9 ϕ	2 x 9 ϕ
BF9	310	8 x 11 ϕ	2 x 11 ϕ
BF12	395	12 x 11 ϕ	2 x 11 ϕ

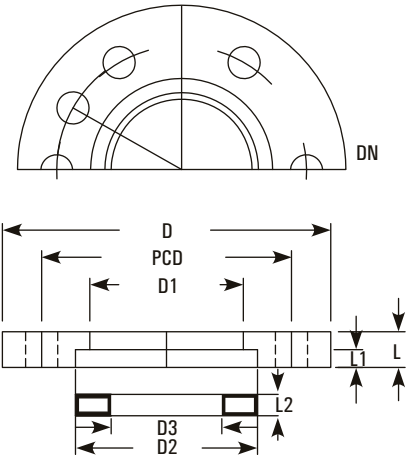

ADAPTOR BELLOW FLANGES

Adaptor bellow flange are used to fit a bellow to a flange having different bolt configuration. These flanges are made of cast iron and are supplied with a split ring.

These are particularly used to fit a bellow with a non-glass equipment like Glass-lined Reactor etc. These are used in BFB, VBF type PTFE bellows.

Adaptor bellow flanges are generally supplied undrilled. However, if specified, these can be supplied drilled as per "Table E", "Table F" and "ASA150" standards.

Undrilling flanges

Cat.Ref.	DN	D	D1	D2	L
BFA0.5	12	80	25	28	6
BFA0.7	15	85	29	37	6
BFA1*	25	115	43	51	7
BFA1.5*	40	150	58	66	7
BFA2*	50	165	70	81	7
BFA3*	80	200	101	112	7
BFA4*	100	220	134	148	8
BFA6*	150	285	186	196	8
BFA9*	225	395	260	282	8
BFA12	300	445	342	363	10

Drilled to Table E

Cat.Ref.	PCD	n x d ϕ
BFA0.5/E	62	4 x 7 ϕ
BFA0.7/E	62	4 x 7 ϕ
BFA1/E	82	4 x 12 ϕ
BFA1.5/E	98	4 x 12 ϕ
BFA2/E	114	4 x 16 ϕ
BFA3/E	146	4 x 16 ϕ
BFA4/E	178	8 x 16 ϕ
BFA6/E	235	8 x 19 ϕ
BFA9/E	324	12x19 ϕ
BFA12/E	406	12x23 ϕ

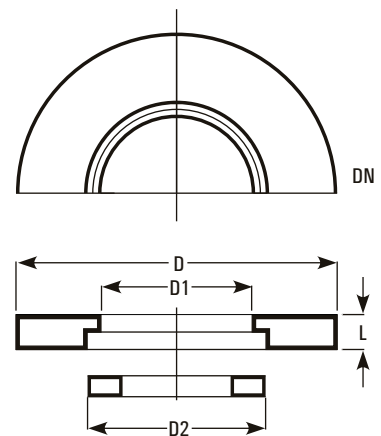

Drilled to Table F

Cat.Ref.	PCD	n x d ϕ
BFA0.5/F	67	4 x 7 ϕ
BFA0.7/F	67	4 x 7 ϕ
BFA1/F	87	4 x 16 ϕ
BFA1.5/F	105	4 x 16 ϕ
BFA2/F	127	4 x 16 ϕ
BFA3/F	165	8 x 16 ϕ
BFA4/F	190	8 x 16 ϕ
BFA6/F	260	12 x 19 ϕ
BFA9/F	356	12 x 23 ϕ
BFA12/F	438	12 x 23 ϕ

Drilled to ASA 150

Cat.Ref.	PCD	n x d ϕ
BFA0.5/A	62	4 x 7 ϕ
BFA0.7/A	62	4 x 7 ϕ
BFA1/A	79	4 x 16 ϕ
BFA1.5/A	98	4 x 16 ϕ
BFA2/A	121	4 x 19 ϕ
BFA3/A	152	4 x 19 ϕ
BFA4/A	190	8 x 19 ϕ
BFA6/A	241	8 x 19 ϕ
BFA9/A	298	8 x 19 ϕ
BFA12/A	432	12x23 ϕ

* marked items are available fast.

STRUCTURE AND SUPPORTS



Glass plants are normally supported in a tubular structure formed of galvanised steel tubes or mild steel with epoxy coated or stainless steel 304 & 316. This type of structure is proved robust and flexible over many years.

STRUCTURE AND SUPPORTS

SUPPORT OF COLUMN

Glass plants and pipeline should be supported correctly. To prevent inducing undesirable stresses in the glass, support should be rigid. When supported, glass should be in compression.

Generally, glass plant and equipment are supported in a rectangular tubular structure. This structure is formed of galvanised mild steel tubing with the cast iron fittings which are described in this catalogue. This type of structure provides enough flexibility for future modifications and is strong enough to support a glass unit.

Following rules should be followed while supporting a glass unit in a tubular structure.

1. The structure must be rigid. To give lateral support it must be braced back to the nearest wall or any rigid feature.
2. All glass columns are build up from a fixed point on which whole weight of the column should be taken.
3. With change in temperature, glass column and tubular structure expands at different rate. Therefore glass unit must be free for vertical movement above the fixed point. Hence, above the fixed point, guides supports should be used to give lateral support.

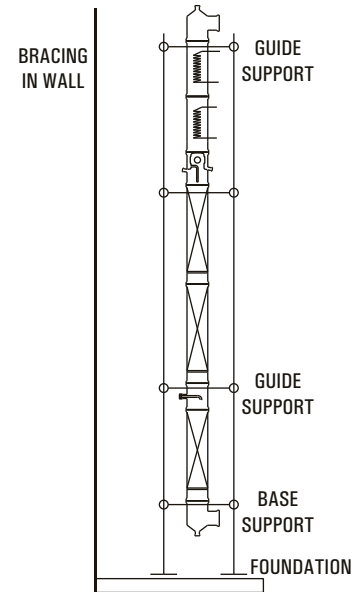

STRUCTURE TUBES, GALVANISED

Tube size

For forming the structure, "B" class galvanised tubes, Mild Steel with Epoxy Coated, Stainless Steel 304 & 316 are used in size of 1/2", 1", 1.1/4", 1.1/2" and 2". Cut tubes are available in required length to form a standard size structure. Cut tubes are provided with rubber plug at both the ends.

NB Inches	NB mm	External Diameter
1/2"	15	19.5
1"	25	32.5
1.1/4"	30	41.5
1.1/2"	40	48.3
2"	50	60.3

Available cut lengths

Structure Dimension	NB (mm)				
	15*	25*	30*	40*	50*
2500	-	2500	-	-	-
3000	-	3000	3000	-	-
3500	-	3500	3500	-	-
4000	-	-	4000	-	-
6000	-	6000	6000	6000	6000

For Vertical installation

2500	-	2500	-	-	-
3000	-	3000	3000	-	-
3500	-	3500	3500	-	-
4000	-	-	4000	-	-
6000	-	6000	6000	6000	6000

For Frames

400	-	365	355	345	335
500	-	465	455	445	435
600	-	565	555	545	535
800	-	765	755	745	735
1000	-	965	955	945	935
1200	-	1165	1155	1145	1135
1500	-	1465	1455	1445	1435

For Support

400	450	450	450
500	550	550	550
600	650	650	650
800	850	850	850
1000	1050	1050	1050
1200	1250	1250	1250

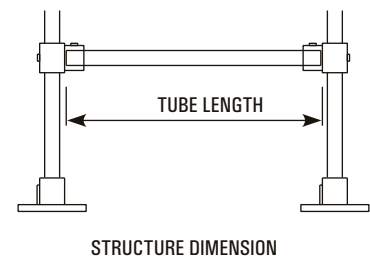

Cat. Ref. TBG (NBmm/Cut length)
 for e.g. TBG 25/365

STRUCTURE AND SUPPORTS

STRUCTURE FITTINGS

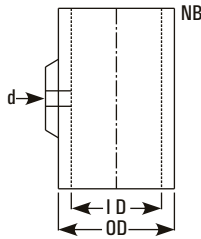

Following structure fittings are available to use with galvanised tubes in order to form a tubular structure for a glass plant. These fittings are made of cast iron. Also available in Stainless Steel 304 & 316 and are suitable to the galvanised tubes described earlier.

These slidable fittings are provided with grub screws to fix it at required position on a galvanised tube.

These fittings are specially made to construct a tubular structure which provides enough flexibility for future modifications without involving any hammering and welding.

STRUCTURE FITTINGS - GENERAL DATA

NB	TUBE DIA	ID	OD	d
25	32.5	35	45	1/2"
30	42.5	45	55	1/2"
40	48.3	51	61	1/2"
50	60.3	63	73	1/2"

STRUCTURE FITTINGS - BASE

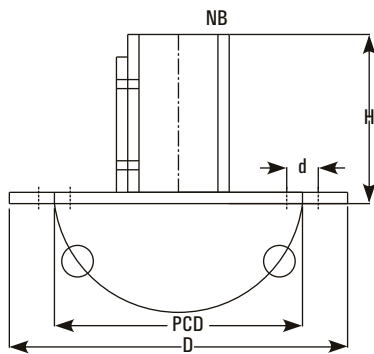

These are to be used with vertical tubes. Holes are provided for foundation.

Cat.Ref.	NB	D	H	PCD	d ϕ
BS25*	25	150	75	110	4 x 14 ϕ
BS30*	30	150	75	110	4 x 14 ϕ
BS40	40	150	75	110	4 x 14 ϕ
BS50	50	175	75	125	4 x 14 ϕ

STRUCTURE FITTINGS - COUPLER

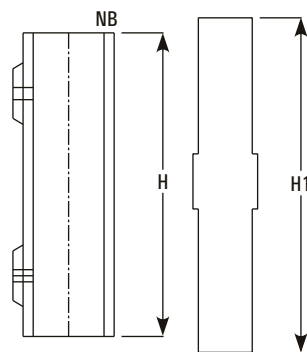

These are generally used to couple the vertical tubes where more length is require.

Cat.Ref.	NB	H	H1
CL25	25	150	200
CL30	30	150	200
CL40	40	150	200
CL50	50	150	200

STRUCTURE FITTINGS - BEND

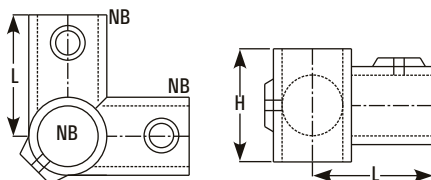

These are used to build frames on vertical tubes.

Cat.Ref.	NB	H	L
BN 25*	25	55	55
BN30*	30	65	70
BN40	40	70	80
BN50	50	85	95

* marked items are available fast.

STRUCTURE AND SUPPORTS

STRUCTURE FITTINGS - TEE

Cat.Ref.	NB	H	L
T25*	25	50	55
T30*	30	65	70
T40	40	70	80
T50	50	85	95

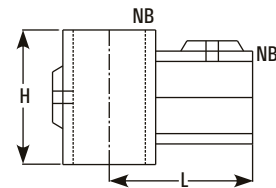

STRUCTURE FITTINGS - DOUBLE BEND

Cat.Ref.	NB	H	L
DBN 25	25	55	55
DBN30	30	65	70
DBN40	40	70	80
DBN50	50	85	95

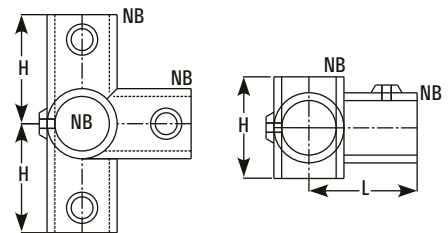

STRUCTURE FITTINGS - DOUBLE TEE

Cat.Ref.	NB	H	L
DT25	25	50	55
DT30	30	65	70
DT40	40	70	80
DT50	50	85	95

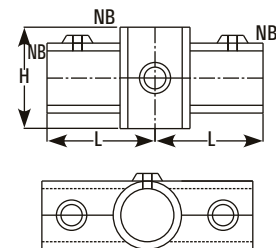

STRUCTURE FITTINGS - EQUAL BRACKET

Cat.Ref.	NB	H	L	L1
EBT25*	25	45	65	50
EBT30*	30	55	80	55
EBT40	40	60	85	60
EBT50	50	70	95	60

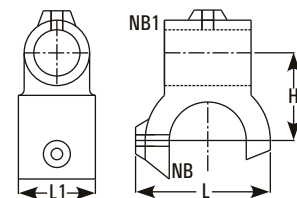

STRUCTURE FITTINGS - UNEQUAL BRACKET

Cat.Ref.	NB	NB1	H	L	L1
UBT25/15*	25	15	40	65	50
UBT30/15*	30	15	50	75	60
UBT40/25	40	25	55	85	60
UBT50/25	50	25	60	95	65

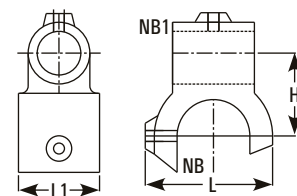

STRUCTURE FITTINGS - CROSS

Cat.Ref.	NB	H	L
X25	25	50	45
X30	30	65	55
X40	40	65	70
X50	50	65	85

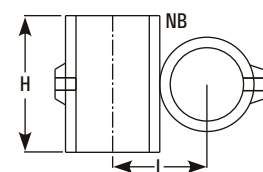

STRUCTURE AND SUPPORTS

STRUCTURE FITTINGS - SUPPORT

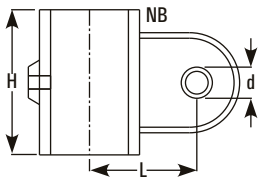

Cat.Ref.	NB	h	L	d
SPT15*	15	30	35	13
SPT25*	25	40	50	13
SPT30*	30	45	57	13
SPT40	40	50	62	13
SPT50	50	55	67	13

STRUCTURE FITTINGS - PLUGS

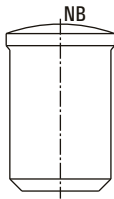

These are used to plug the open ends of galvanised tubes.

Cat. Ref.	NB
PLUG15*	15
PLUG25*	25
PLUG30*	30
PLUG40	40
PLUG59	50

STRUCTURE FITTINGS - STUDS

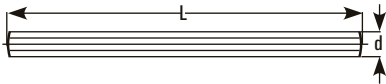

These are used as screwed rods with supports

Cat.Ref.	d	L
STUD5/16-150*	5/16"	150
STUD3/8-150*	3/8"	150
STUD1/2-200	1/2"	200

STRUCTURE DIMENSIONS

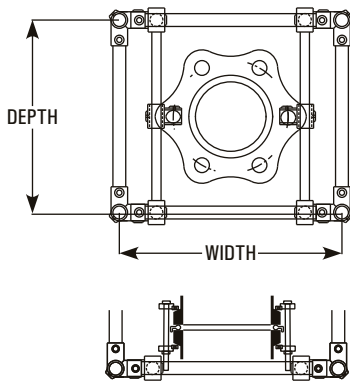

FOR COLUMNS

DN	Recommended tube size NB (mm)	Minimum Structure size Depth X Width
80	25	500 x 500
100	25	500 x 500
150	25,30	600 x 600
225	30	800 x 800
300	30	800 x 800
400	30	1000 x 1000
450	30,40	1000 x 1000
600	40,50	1200 x 1200

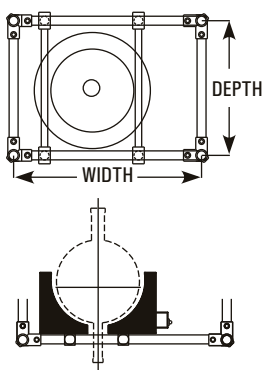

FOR VESSELS (IN HEATING MENTLES)

Size (Litres)	Recommended tube size NB (mm)	Minimum Structure size Depth X Width
20	25	400 x 600
50	25	600 x 800
100	25,30	800 x 800
200	30	800 x 1000

* marked items are available fast.

STRUCTURE AND SUPPORTS

FOR VESSELS (IN HEATING BATHS)

Size (Litres)	Recommended tube size NB (mm)	Minimum Structure size Depth X Width
20	25	500 x 600
50	25	600 x 800
100	25,30	800 x 1000
200	30	800 x 1200

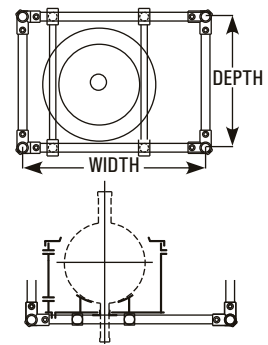

FOR VESSELS (IN VESSEL HOLDERS)

Size (Litres)	Recommended tube size NB (mm)	Minimum Structure size Depth X Width
20	25	500 x 600
50	25	600 x 800
100	25,30	1000 x 1000
200	30	1000 x 1000

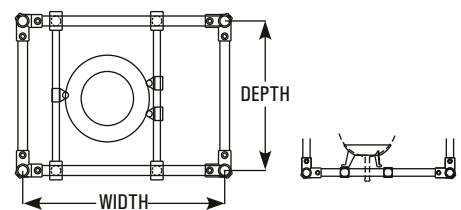

COLUMN BASE SUPPORT FRAMES

These channel frames are used as fixed support in erection of columns. These are supplied with full threaded jacking rods and U bolts.

Cat.Ref.	PCD	L1	L	H
FCSH225	310	1000	800	75
FCSH300	395	1000	800	75
FCSH400	495	1200	1000	75
FCSH450	585	1200	1000	100
FCSH600	710	1400	1200	100

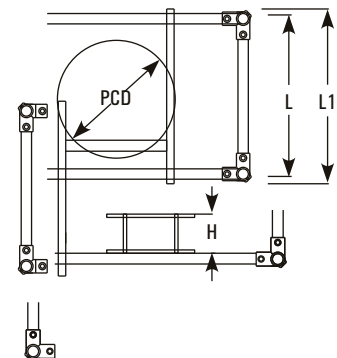

STRUCTURE AND SUPPORTS

GROUTING OF BASE

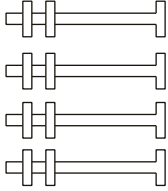
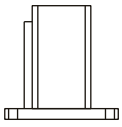

1. Take one Cast Iron BASE and four foundation Bolts, each with 2 nuts.

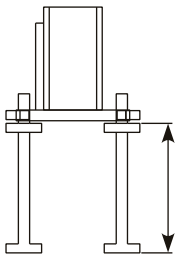

2. Fit the bolts in BASE so that base is raised upto 150mm from head of bolts.

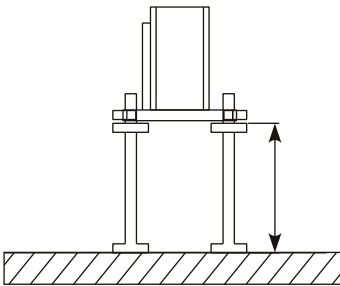

3. Put this assembly on the floor and prepare a rough surface for proper bonding of grouting.

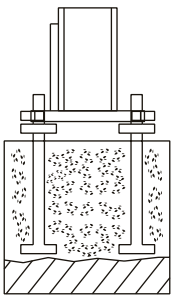

4. Make a concrete block over the bolts of about 200 x 200 mm upto the base of BASE i.e. 150mm high.

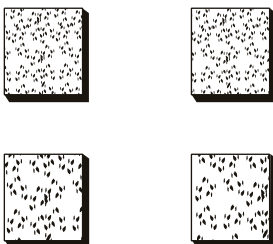

5. Prepare separate block for each BASE instead of making one big common block. For all BASES.

STRUCTURE AND SUPPORTS

ASSEMBLING OF STRUCTURE



- ① Mark the position of required fittings on all the Vertical tubes, slide them in correct sequence and lightly Tighten.

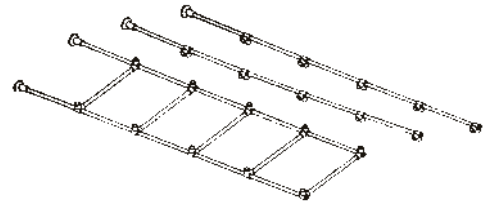

- ② Assemble one side frame of the structure by adding the cross tubes between two vertical tubes.

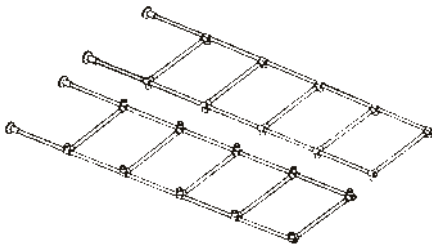

- ③ Assemble other side frame of the structure by adding the cross tubes between other two vertical tubes.

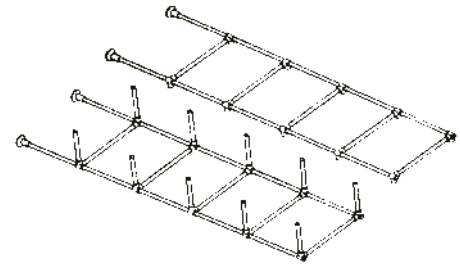

- ④ Build up the cross tubes in one side frame and Tighten lightly.

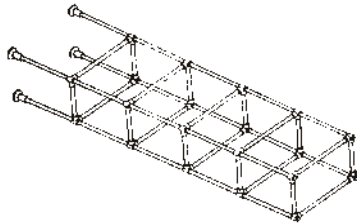

- ⑤ Add the other side frame on it and tighten all the fittings firmly.

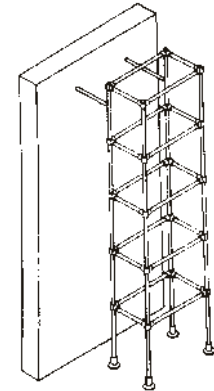

- ⑥ Hoist the structure and brace it to some existing rigid feature.

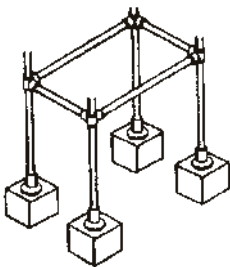

- ⑦ Grout the foundation bolts and fix the structure bases with that.

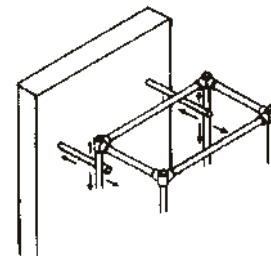

- ⑧ Adjust bracing to obtain a correct plumb in Structure.

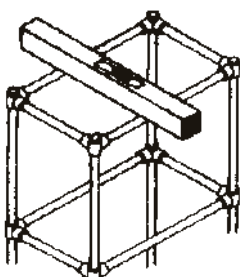

- ⑨ Adjust the horizontal frames in correct level.

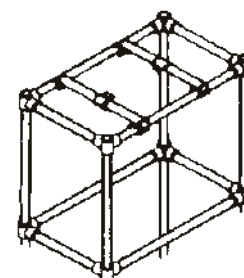

- ⑩ Assemble the support tubes at their positions.

SIGHT GLASS

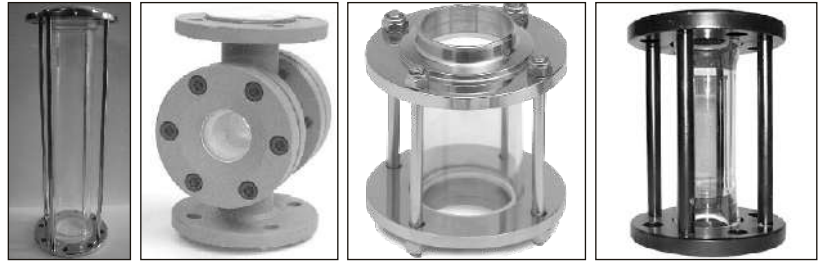

Sight glass is a device used between any kind of non transparent pipelines to observe the flow of liquid. This can be used both in horizontal as well as vertical pipeline. Sight glass is constructed in such a way that it gives a complete view from every angle.

A sight glass consists of one glass pipe section, one metal frame, a pair of PTFE bushes and washers and an acrylic cover. Borosilicate pipe section is highly heat resistant, has excellent chemical resistance and has low thermal expansion. Metal frame is composed of two flanges which are welded with studs so that the stresses and vibrations of the pipeline do not transfer to the glass pipe section. Its check nut keeps the glass pipe section in compression and provides ease in replacement.

PTFE bushes on both sides of glass pipe section ensures that liquid in the pipeline does not come in contact with metal frame. PTFE washers are used as gaskets while fitting the sight glass in the pipeline. Acrylic cover covers the glass pipe section and protects it from outer damages.

Sight glass can be supplied with MS/SS304/SS316 frame with any standard drilling.

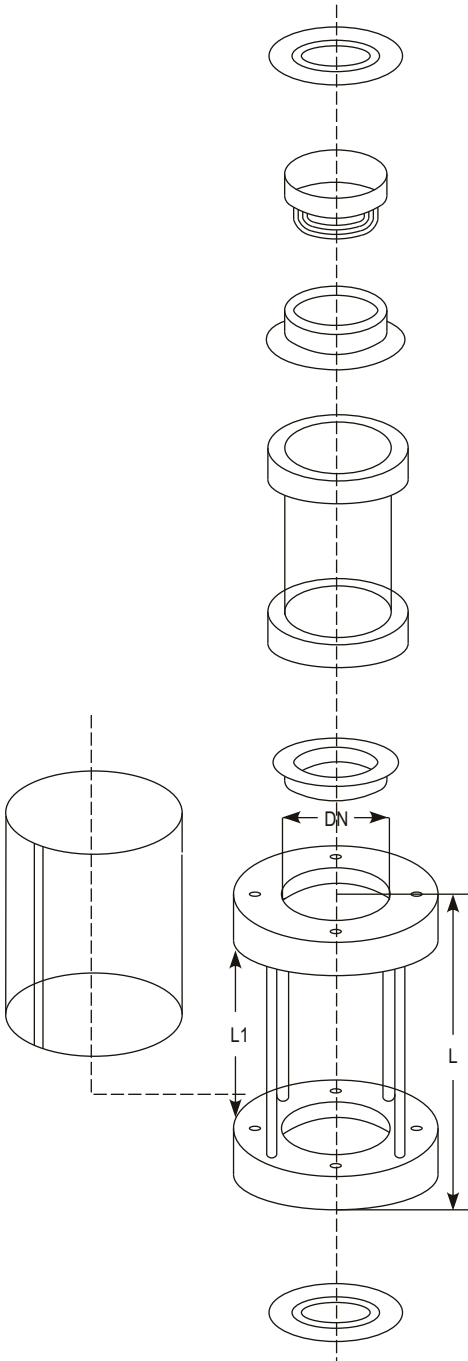

MS FRAME SIGHT GLASS

DN	L	L1	Cat.Ref. Table E	Cat.Ref. Table F	Cat.Ref. Table ASA
25	192	150	SG1/E	SG1/F	SG1/A
40	192	150	SG1.5/E	SG1.5/F	SG1.5/A
50	192	150	SG2/E	SG2/F	SG2/A
80	192	150	SG3/E	SG3/F	SG3/A
100	192	150	SG4/E	SG4/F	SG4/A
150	192	150	SG6/E	SG6/F	SG6/A

SS 304 FRAME SIGHT GLASS

DN	L	L1	Cat.Ref. Table E	Cat.Ref. Table F	Cat.Ref. Table ASA
25	192	150	SG1/E/304	SG1/F/304	SG1/A/304
40	192	150	SG1.5/E/304	SG1.5/F/304	SG1.5/A/304
50	192	150	SG2/E/304	SG2/F/304	SG2/A/304
80	192	150	SG3/E/304	SG3/F/304	SG3/A/304
100	192	150	SG4/E/304	SG4/F/304	SG4/A/304
150	192	150	SG6/E/304	SG6/F/304	SG6/A/304

SS 316 FRAME SIGHT GLASS

DN	L	L1	Cat.Ref. Table E	Cat.Ref. Table F	Cat.Ref. Table ASA
25	192	150	SG1/E/316	SG1/F/316	SG1/A/316
40	192	150	SG1.5/E/316	SG1.5/F/316	SG1.5/A/316
50	192	150	SG2/E/316	SG2/F/316	SG2/A/316
80	192	150	SG3/E/316	SG3/F/316	SG3/A/316
100	192	150	SG4/E/316	SG4/F/316	SG4/A/316
150	192	150	SG6/E/316	SG6/F/316	SG6/A/316

STANDARD UNITS



INTRODUCTION

Standard Units/ Assemblies are multi-purpose units having flexibility of utility. These units have been standardized by incorporating all basic & essential features such as heating, stirring, condensation, fractionation, cooling etc. for multi-purpose use. Therefore, though termed "Standard Units" from constructional view point they actually serve as "Flexi Units" from utility point of view.

These units find use in educational institutions, R&D centers and industries. They can be conveniently and quickly modified according to specific process needs due to modular construction. Borosilicate glass offers additional benefits of universal corrosion resistance, visibility and cleanliness.

STANDARD UNITS

1. Glass Reactor With Metal Jacket
2. Simple Distillation Unit
3. Reaction Unit
4. Fraction Distillation Unit
5. Reaction Distillation Unit
6. Liquid-Liquid Extraction Unit
7. Solid-Liquid Extraction Unit
8. Assembly over GLR
9. Gas Scrubber
10. Multi Purpose Unit
11. Mobile Mixing System
12. Essential Oil Distillation Unit
- 13 Agitated Glass Nutsche Filter, Peptide Synthesizer
- 14 HCL Adiabatic Absorption
- 15 Lab Glass Reactor

GLASS REACTOR WITH METAL JACKET

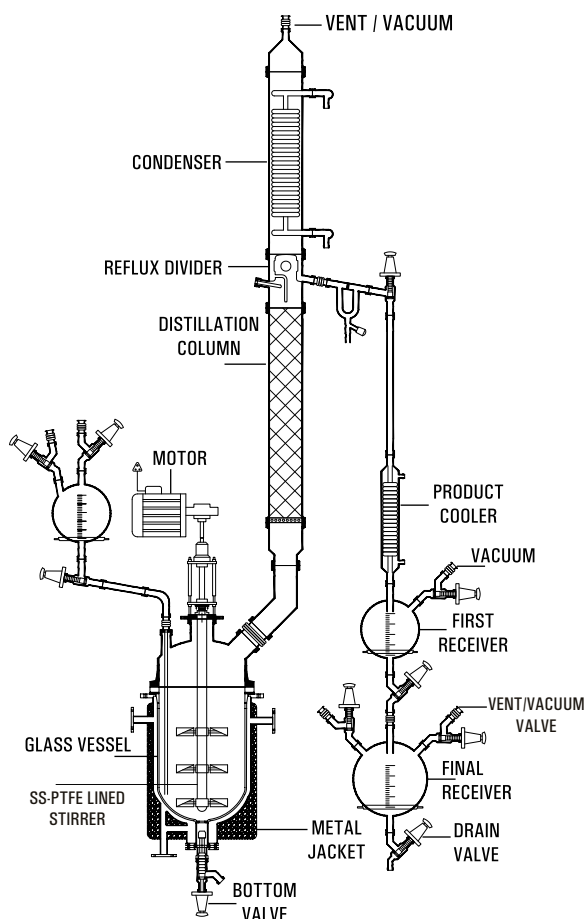

According to the customer's requirements and standard, we manufacture jacketed glass reactor which has many functions to satisfy kinds of experiments.

Glass Reactor with Metal Jacket for chemical & pharmaceutical industries for process development. Glass reactor will have metal jacket and metal insulation.

Glass Metal jacketed Reactor 5-200 liter

Pressure: - up to 1 Bar

Temperature: -50°C to +200°C

Material: Borosilicate glass 3.3 /PTFE/ SS 316.

Key Features:

- Reactor lift for easy opening i.e optimised for easy vessel cleaning.
- Temperature monitoring and control.
- Gas purging available.
- Vacuum / exhaust piping arrangement.
- Additional feeders / receivers as per requirement.
- Solid feeding arrangement.
- Ready for Cryogenic reactions (-50°C).
- Mixed systems with pressure reactor and vacuum distillation.

STANDARD UNITS

SIMPLE DISTILLATION UNIT

It consists of a vessel mounted in a heating bath and fitted with a condenser for condensing the vapours. A receiver with drain valve can be added for receiving the condensate.

The units are available in vessel sizes of 20, 50, 100, 200, 300 & 500 L and is suitable for operation under atmospheric pressure and full vacuum.

Unit Cat.Ref.	Reactor Capacity	Bath KW	Vapour Line	Condenser M ²
SDU20	20 L	4.0	80 DN	0.35
SDU50	50 L	6.0	100 DN	0.50
SDU100	100 L	9.0	150 DN	1.50
SDU200	200 L	12.0	150 DN	1.50
SDU300	300 L	18.0	225 DN	2.50
SDU500	500L	24.0	300 DN	4.00

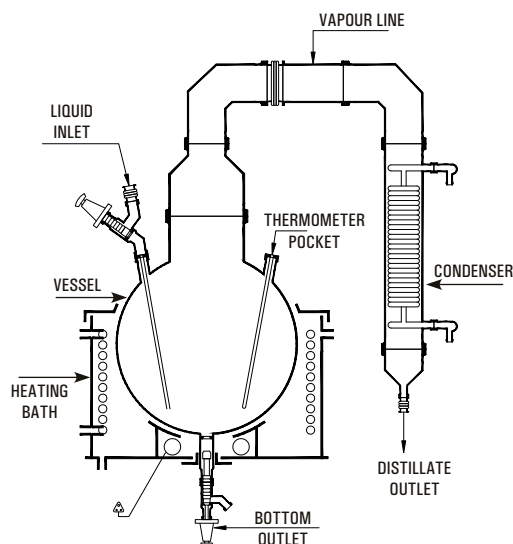

REACTION UNIT

This unit is used for carrying out reactions under stirred condition and with provision for simple reflux distillation.

The reaction vessel is mounted in a heating bath and fitted with addition vessel, motor-driven stirrer and provision for condensation with refluxing. The product is sub-cooled and collected in a receiver.

The units are available in vessel sizes of 20, 50, 100, 200, 300 & 500 L and is suitable for operation under atmospheric pressure and full vacuum.

Unit Cat.Ref.	Reactor Capacity	Bath KW	Addition Vessel	Vapour Line	Condenser HTA M ²	Cooler HTA M ²	Receiver Size
RDU20	20 L	4.0	2 L	80 DN	0.35	0.10	5 L
RDU50	50 L	6.0	5 L	100 DN	0.50	0.20	10 L
RDU100	100 L	9.0	10 L	150 DN	1.50	0.35	20 L
RDU200	200 L	12.0	20 L	150 DN	1.50	0.35	20 L
RDU300	300 L	18.0	20 L	225 DN	2.50	0.50	20 L
RDU500	500 L	24.0	50 L	300 DN	4.00	0.70	50 L

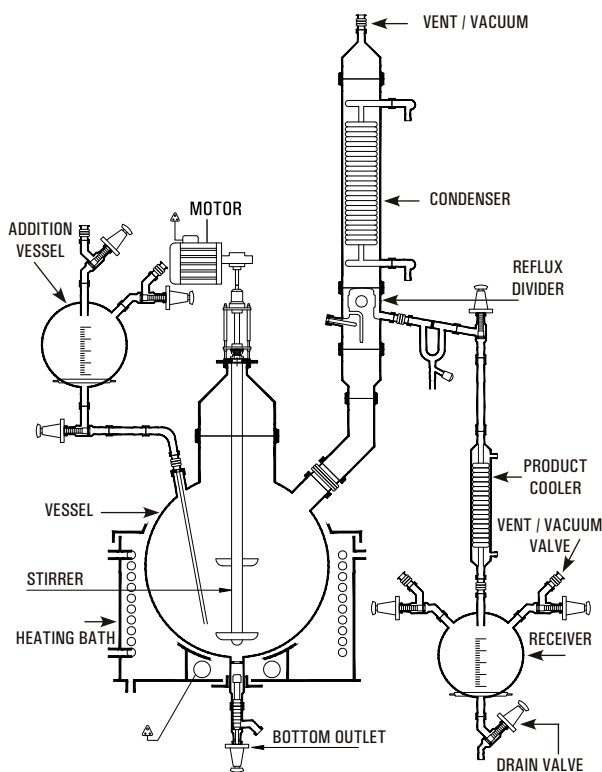

STANDARD UNITS

FRACTIONAL DISTILLATION UNIT

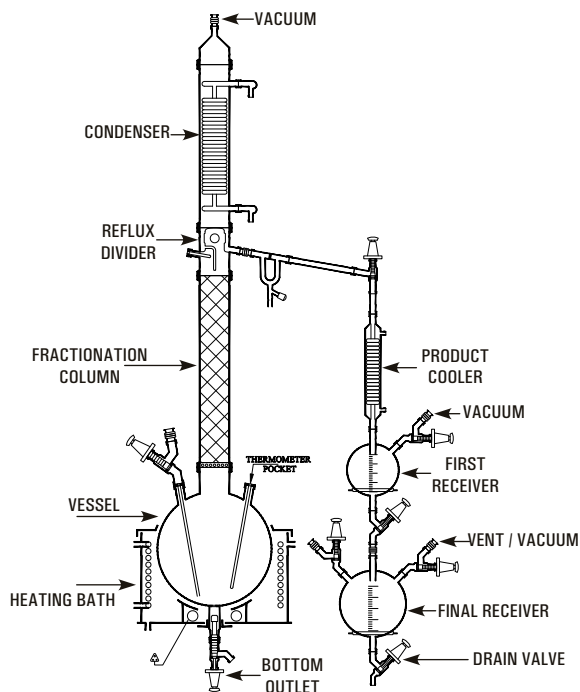

This is essentially a compact batch-type fractional distillation unit in which the reboiler consists of a vessel mounted in a heating bath and with a packed column above. The vapours from top is condensed and can be refluxed as per requirement.

The top product is sub-cooled and collected in receivers. The bottom product is finally drained from the reboiler through a drain valve.

The units are available in vessel sizes of 20, 50, 100, 200, 300 & 500 L and is suitable for operation under atmospheric pressure and full vacuum

Unit Cat.Ref	Reactor Capacity	Bath KW	Vapour Line	Condenser HTA M ²	Cooler HTA M ²	Receiver Size
FDU20	20 L	4.0	80 DN	0.35	0.10	2L , 5L
FDU50	50 L	6.0	100 DN	0.50	0.20	5L , 10L
FDU100	100 L	9.0	150 DN	1.50	0.35	10L , 20L
FDU200	200 L	12.0	150 DN	1.50	0.35	20L , 20L
FDU300	300 L	18.0	225 DN	2.50	0.50	20L , 20L
FDU500	500 L	24.0	300 DN	4.00	0.70	20L , 50L

REACTION DISTILLATION UNIT

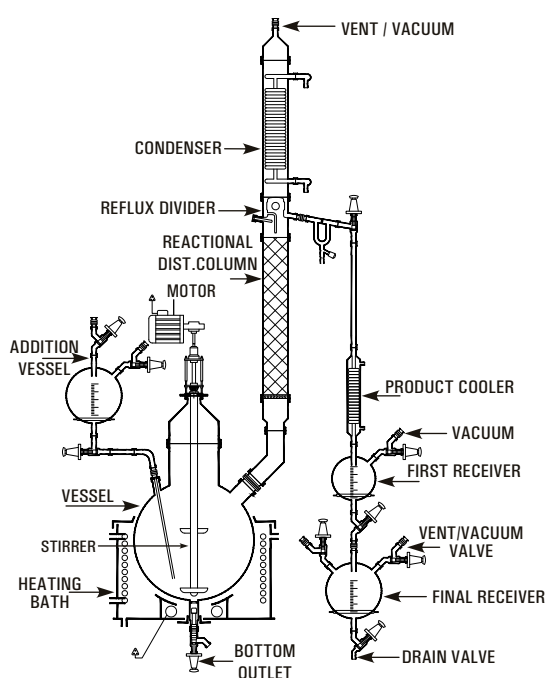

This is a versatile unit and can be used as Reaction Distillation Unit, Fractional Distillation Unit or a combination of both. All features of Reaction Distillation Unit and Fractional Distillation Unit are incorporated.

The units are available in vessel sizes of 20, 50, 100, 200, 300 & 500 L and is suitable for operation under atmospheric pressure and full vacuum.

Unit Cat.Ref	Reactor Capacity	Bath KW	Addition Vessel	Vapour Line	Condenser HTA M ²	Cooler HTA M ²	Receiver Size
FRU20	20 L	4.0	2 L	80 DN	0.35	0.10	2L, 5L
FRU50	50 L	6.0	5 L	100 DN	0.50	0.20	5L, 10L
FRU100	100 L	9.0	10 L	150 DN	1.50	0.35	10L, 20L
FRU200	200 L	12.0	20 L	150 DN	1.50	0.35	10L, 20L
FRU300	300 L	18.0	20 L	225 DN	2.50	0.50	20L, 20L
FRU500	500 L	24.0	50 L	300 DN	4.00	0.70	50L, 50L

STANDARD UNITS

LIQUID-LIQUID EXTRACTION UNIT

Liquid extraction, sometimes called solvent extraction, is the separation of constituents of a liquid solution by contact with another insoluble liquid. The unit described here is for a semi-batch operation.

The liquid to be extracted is poured into an extraction vessel. Solvent is boiled in a reboiler vessel and condensed in an overhead condenser, the condensed liquid collecting in a reflux divider and passing through pipework to the extraction vessel. The pipework incorporates valves in order that the solvent can enter the extraction vessel at either the base or the top, depending on the relative densities of the solvent and liquid to be extracted. The solvent and the extracted liquid pass back to the reboiler and the process is repeated until the extraction is complete. The extraction vessel is then drained and the solvent evaporated from the reboiler vessel and collected in the extraction vessel enabling the two liquids to be drained from their respective vessels.

The units are available in vessel sizes of 20, 50, 100, 200 & 300 L and is suitable for operation under atmospheric pressure.

Unit Cat.Ref.	Reactor Capacity	Bath KW	Vapour Line	Extraction Vessel	Condenser M ²
LLU10	10 L	3.00	40mmx1m	10 L	0.35
LLU20	20 L	4.00	50mmx1m	20 L	0.50
LLU50	50 L	6.00	80mmx1m	50 L	1.50
LLU100	100 L	9.00	100mmx1m	100 L	1.50
LLU200	200 L	12.00	150mmx1m	200 L	2.25
LLU300	300 L	18.00	225mmx1m	300 L	4.00

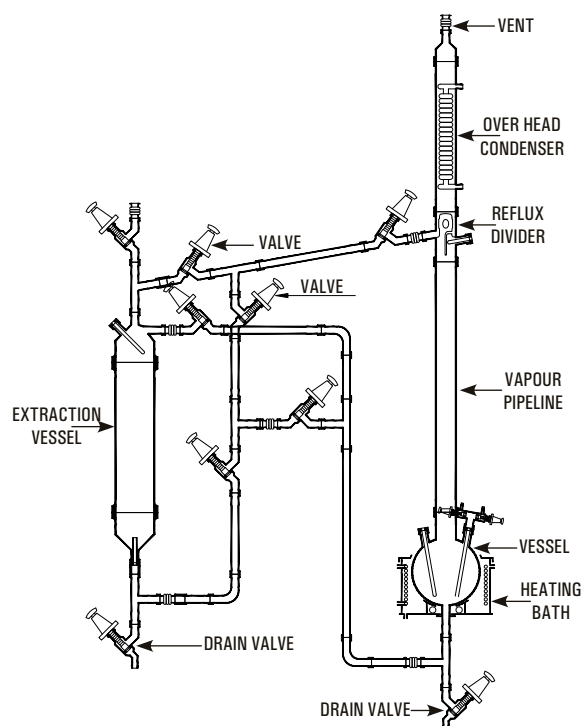

SOLID-LIQUID EXTRACTION UNIT

This operation involves preferential solubilising of one or more soluble constituents (solutes) of a solid mixture by a liquid solvent. The unit described here is for a semi-batch operation.

The solid to be extracted is put inside a glass fiber bag and placed in an extraction vessel. Solvent from the reboiler is continuously evaporated, condensed and circulated through a reflux divider by means of piping network and valves. When desired/ steady concentration of solute is achieved in the solution the operation is discontinued. The solution is drained off and collected for further use.

After charging fresh solid in fiber bag and solvent in reboiler, the cycle can be restarted again.

The units are available in vessel sizes of 20, 50, 100, 200 & 300 L and is suitable for operation under atmospheric pressure.

Unit Cat. Ref.	Reactor Capacity	Bath KW	Vapour Line	Extraction Vessel	Condenser M ²
SLU10	10 L	3.00	40mmx1m	10 L	0.35
SLU20	20 L	4.00	50mmx1m	20 L	0.50
SLU50	50 L	6.00	80mmx1m	50 L	1.50
SLU100	100 L	9.00	100mmx1m	100 L	1.50
SLU200	200 L	12.00	150mmx1m	200 L	2.25
SLU300	300 L	18.00	225mmx1m	300 L	4.00

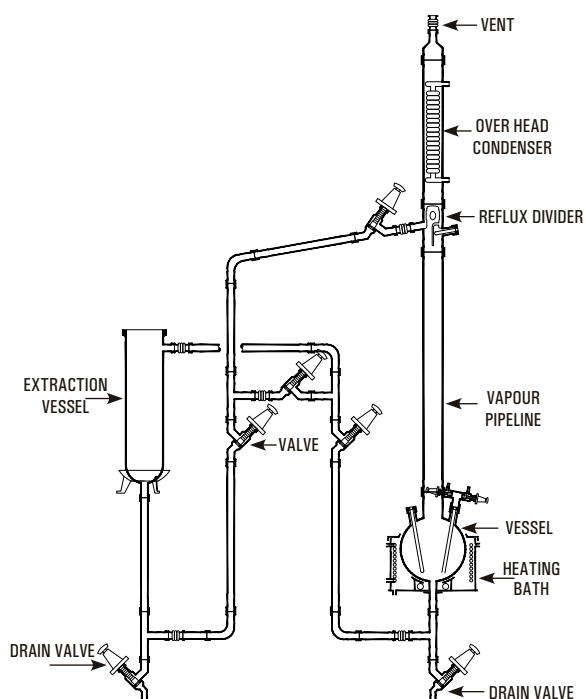

ASSEMBLIES OVER GLASS LINED REACTOR

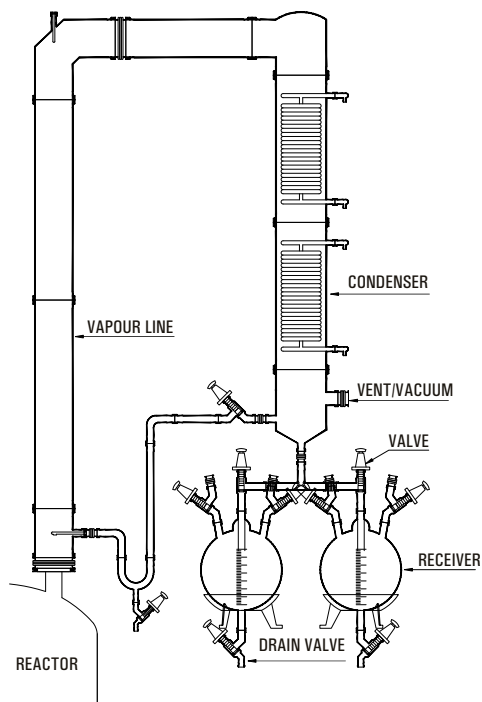

Glass Lined Reactors are used instead of glass reactors specially when scale of operation is large and relatively high pressure steam is to be used as heating media. Quite often assemblies like Simple Distillation Unit, Reaction Distillation Unit, Fractional Distillation Unit etc. are installed above glass lined reactors. The basic features of these assemblies remain the same but glass shell and tube heat exchanger is preferred due to large scale of operation. A typical fractional distillation unit type assembly over GLR is shown in adjacent figure.

Cat.Ref.	Reactor Cap.	Vapour column	Condenser HTA M ²
GRU 250	250 L	80mmX1.5m	1.5X2
GRU 500	500 L	100mmX2m	1.5X2
GRU 1000	1000 L	100mmX2m	2.5X2
GRU 2000	2000 L	150mmX3m	2.5X3
GRU 3000	3000 L	150mmX2m	4.0X2

GAS SCRUBBER

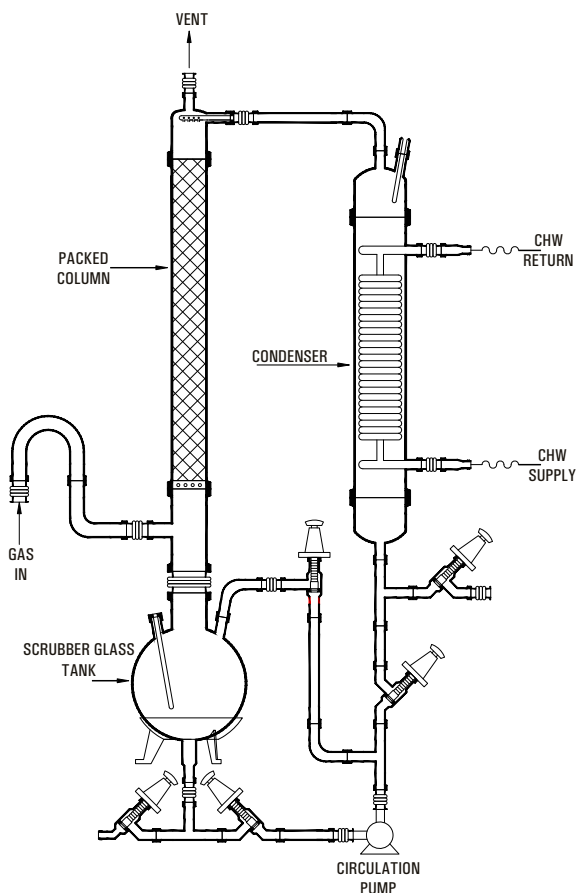

Pilot Plant Gas Scrubber for various gases likes HCl, Cl₂, SO₂, Br₂, HBr, NO_x etc or any other corrosive gases. These scrubbers use the media as water / Aq. NaOH / any other suitable solvent which can neutralise the exhaust gases. Our Pilot plant scrubber are ranging from 20L vessel capacity to 500L vessel capacity and scrubber diameter from 80DN to 300DN.

We can also design and offer big size scrubber in Glass up to 800DN (i.e. 400/450/600/800DN). Our scrubber will be having inbuilt Cooler to remove the heat of absorption. We also offer mini Blower of PP/FRP on request along with the Pilot Plant Scrubber.

Pilot Plant Gas scrubber are mainly used in pharmaceutical, chemical, refinery & other industries. Glass scrubber offer process visibility as well as excellent corrosion resistance. Being a Glass Scrubber pressure drop across the scrubber will be minimized.

Cat.Ref.	Size	Vessel	Condenser (M ²)
PGS3	80DN	20 L	0.5
PGS4	100DN	50 L	1.5
PGS6	150DN	100 L	2.5
PGS8	200DN	200 L	5
PGS12	300DN	300 L	8

STANDARD UNITS

MULTI PURPOSE UNIT

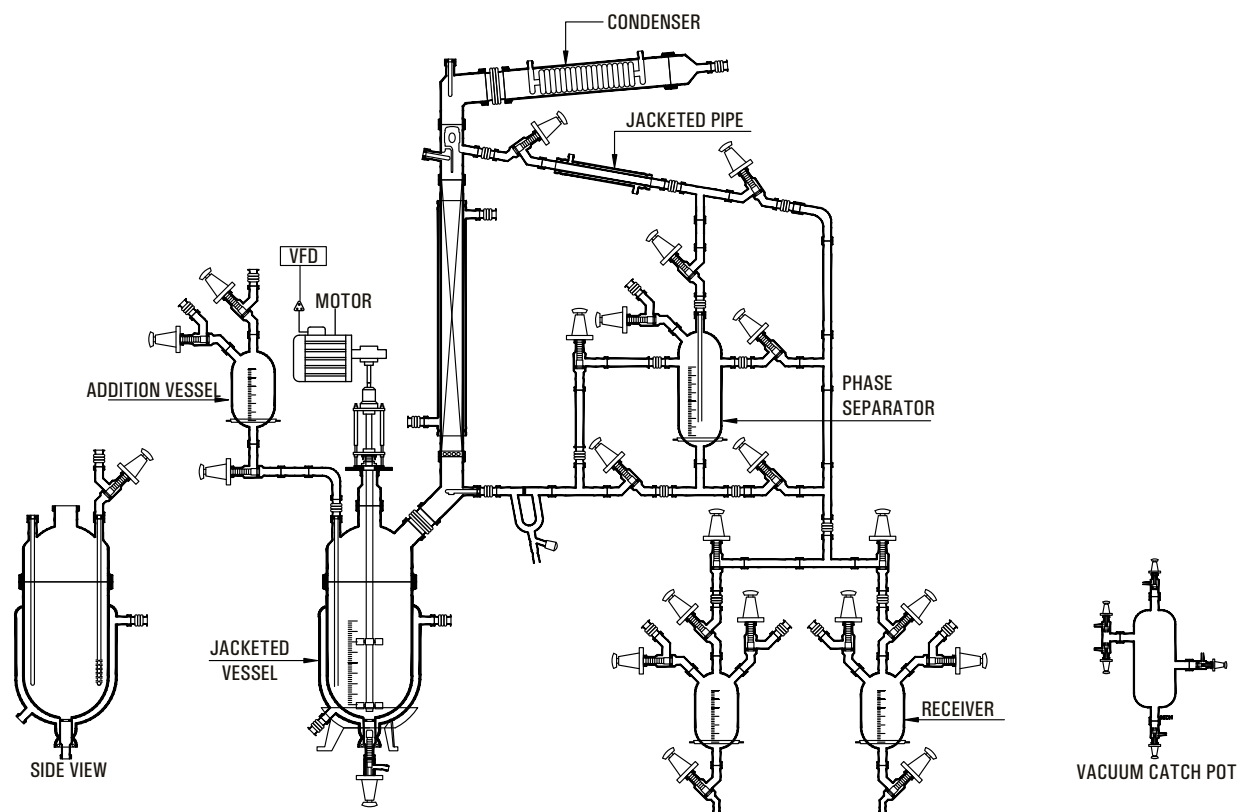

G Multipurpose pilot plant for chemical and pharmaceutical industries for process development, scale-up, process simulation and kilo-scale cGMP production in batch and semi-batch operation. The pilot plant used for chemical processing includes solid charging, liquid charging, reaction, heating / cooling, rectification, auto / manual reflux arrangement, layer separation, product cooler, vacuum catch pot, vacuum header etc.

G The multipurpose pilot plant designed in such a way that we can modify the same easily as per process requirement.

Available with

- G Jacketed full glass reactor / Cylindrical full glass reactor with Oil heating cooling bath / Spherical full glass reactor with Oil heating cooling bath
- G Multipurpose glass distillation overhead
- G Stainless steel / MS epoxy coated / MS painted frame supporting
- G Flame proof / Non flame proof / cGMP / non GMP models available
- G Excellent corrosion resistant.
- G Temp. Controller.
- G Gas purging, solid charging / multi liquid addition.
- G Vacuum / exhaust piping
- G Additional feeders / receivers
- G Solid feeding

Unit Cat. Ref.	Reaction Capacity	Bath KW	Addition Vessel	Vapour Line	Condenser HTA (M ²)	Cooler HTA (M ²)	Receiver Size
MPU 20	20 L	4.0	2 L	80 DN	0.35	0.10	2L, 5L
MPU 50	50 L	6.0	5 L	100 DN	0.50	0.20	5L, 10L
MPU 100	100 L	9.0	10 L	150 DN	1.50	0.35	10L, 20L
MPU 200	200 L	12.0	20 L	150 DN	1.50	0.35	10L, 20L
MPU 300	300 L	18.0	20 L	225 DN	2.50	0.50	20L, 20L
MPU 500	500 L	24.0	50 L	300 DN	4.00	0.70	50L, 50L

MOBILE MIXING SYSTEM

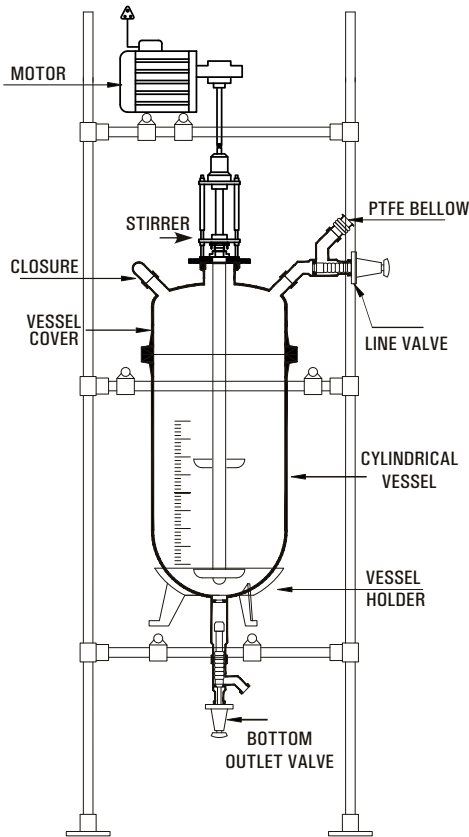

Cylindrical Mixing Reactor

Glass Reactors are ideally used for wide applications in laboratory, pilot plant & for small-scale production. They reduce the need for investment in permanent installations & also reduce the pressure & temperature losses resulting from pipeline installation.

These reactors are available with spherical shape & in cylindrical shape. These reactors are also available in cylindrical jacketed form.

Cat.Ref.	Vessel Ref.	Nominal Cap.(l)
CGR 20	VZ 20/12	20
CGR 50	VZ 50/16	50
CGR 100	VZ 100/18	100
CGR 150	VZ 100/18	150
CGR 200	VZ 200/18	200
CGR 300	VZ 300/24	300

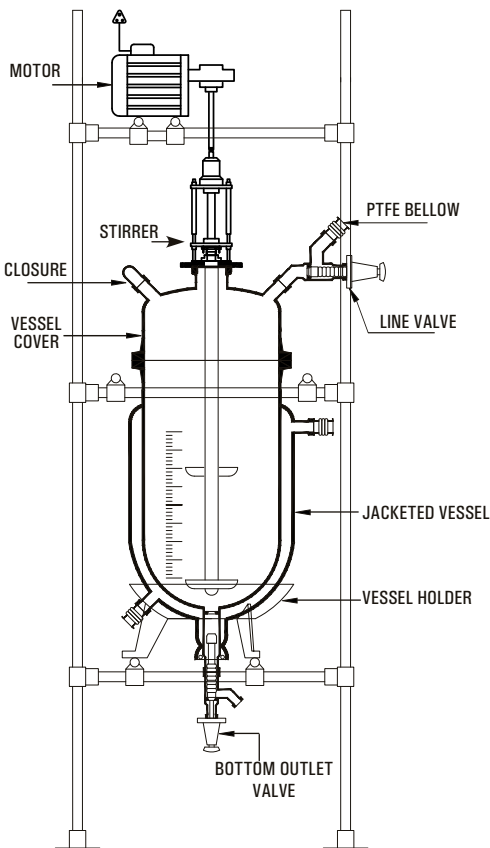

Jacketed Mixing Reactor

The systems are available with different options, depending upon their size & their utility. Our Technical Department will glad to assist you in finding a suitable solution for your process requirement.

1. Stirrer Drive: Non-Flameproof or Flameproof Motor, 192 RPM with speed regulator.
2. Stirrer material of construction: Glass or PTFE Lined.
3. Stirrer shape: Glass Impeller Stirrer with PTFE Blades, Vortex Stirrer, propeller stirrer & anchor stirrer.
4. Stirring Assembly: Stirring Assembly with bellow seal or with mechanical seal.
5. Supporting Structure : Carbon Steel, Epoxy coated Carbon Steel, Stainless Steel 304 & Stainless Steel 316. All structure are available in Trolley mounted form.
6. Closing Valve: Drain Valve or Flush Bottom Outlet Valve.

Cat.Ref.	Vessel Ref.	Nominal Cap.(l)
JGR 5	VZD 5/6	5
JGR 10	VZD 10/9	10
JGR 20	VZD 20/12	20
JGR 30	VZD 30/12	30
JGR 50	VZD 50/16	50

STANDARD UNITS

ESSENTIAL OIL DISTILLERS

An essential oil is a concentrated hydrophobic liquid containing volatile (easily evaporated at normal temperatures) chemical compounds from plants. Essential oils are also known as volatile oils, ethereal oils, aetherolea, or simply as the oil of the plant from which they were extracted.

Essential oils are generally extracted by distillation, often by using steam. We provide two modes through which one can produce essential oils viz. Steam Distillation Unit & Vacuum Distillation Unit.

1. Steam Distillation Unit

The units are available in vessel sizes of 10, 20, 50, 100 & 200 L and is suitable for operation under atmospheric pressure and full vacuum.

Steam distillation as a whole is a separation process which consists of distilling water together with other volatile and non-volatile components. The water is heated up in the spherical vessel separately and the steam from the boiling water goes into the reactor where it reacts with the masses of trees and plants and further carries the vapor of the volatiles to a condenser, where both are cooled and return to the liquid or solid state; while the non-volatile residues remain behind in the reactor.

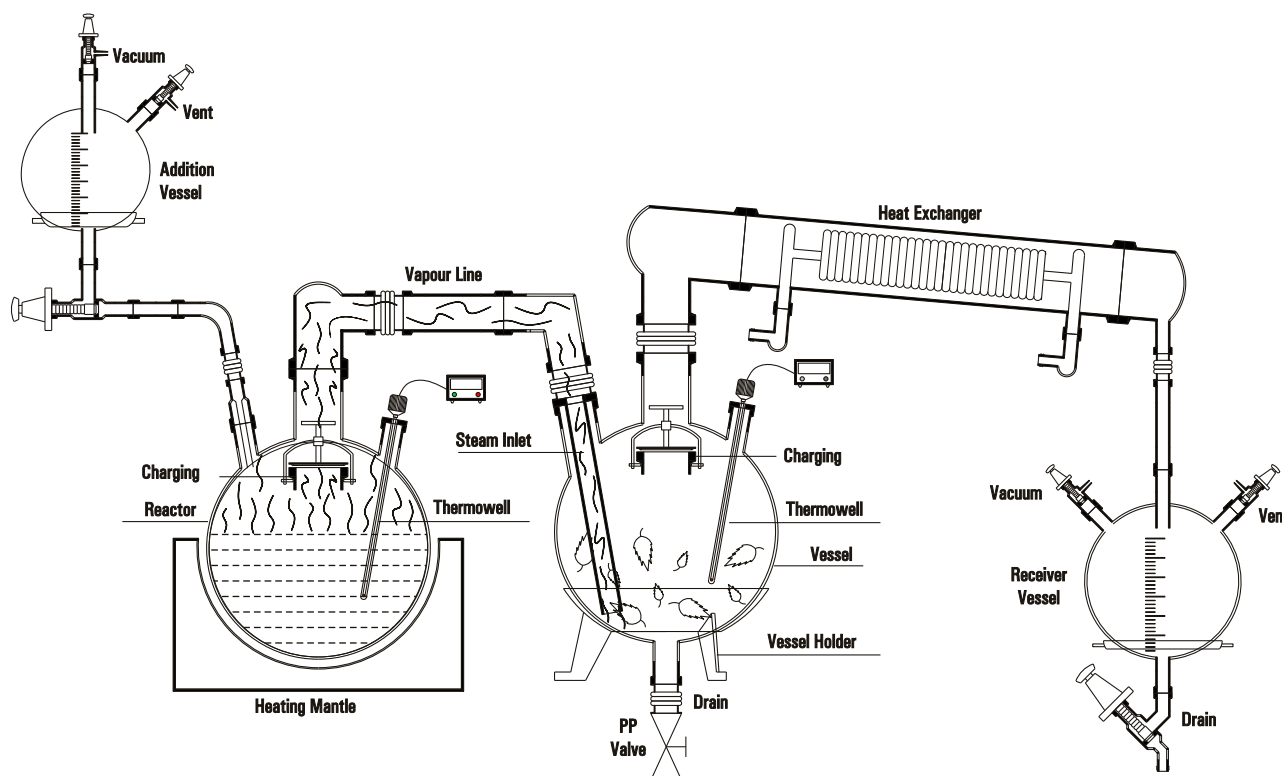

Unit Cat.Ref.	Reactor Capacity	Mantle KW	Addition Vessel	Condenser HTA (M ²)	Receiver Vessel
EOSD 10	10 L	1	5 L	0.35	5 L
EOSD 20	20 L	1.8	5 L	0.50	5 L
EOSD 50	50 L	3.6	20 L	1.50	20 L
EOSD 100	100 L	5.4	20 L	1.50	20 L
EOSD 200	200 L	8.1	50 L	2.25	50 L

2. Vacuum Distillation Unit

Vacuum distillation is a distillation performed under reduced pressure, which allows the purification of compounds not readily distilled at ambient pressures or simply to save time or energy. This technique separates compounds based on differences in boiling points. This technique is used when the boiling point of the desired compound is difficult to achieve or will cause the compound to decompose. A reduced pressure decreases the boiling point of compounds. The steam from the boiling water carries the vapor of the volatiles to a condenser, where both are cooled and return to the liquid or solid state; while the non-volatile residues remain behind in the boiling container.

Unit Cat.Ref.	Reactor Capacity	Mantle KW	Addition Vessel	Condenser HTA (M ²)	Receiver Vessel
EOVD 10	10 L	1	5 L	0.35	5 L
EOVD 20	20 L	1.8	5 L	0.50	5 L
EOVD 50	50 L	3.6	20 L	1.50	20 L
EOVD 100	100 L	5.4	20 L	1.50	20 L
EOVD 200	200 L	8.1	50 L	2.25	50 L

AGITATED GLASS NUTSCHE FILTER/ PEPTIDE SYNTHESIZER

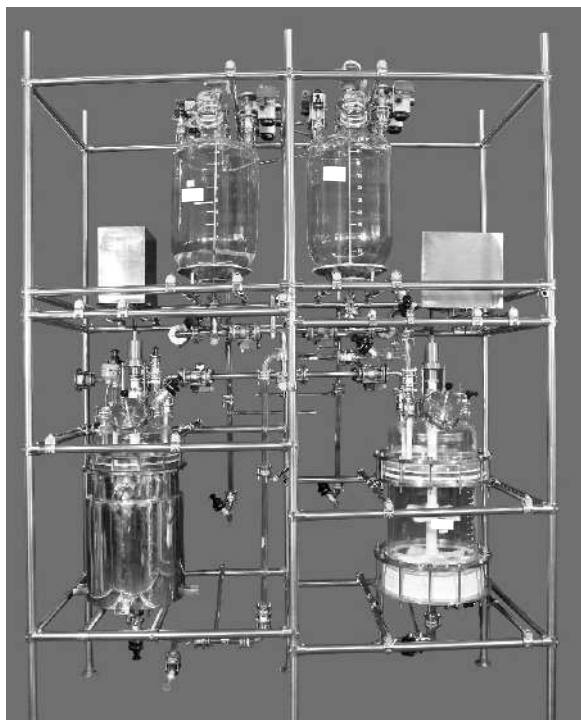

Agitated Glass Nutsche Filter is a closed vessel designed to separate solid and liquid by filtration under vacuum. The closed system ensures odourless contamination free and non-polluting working conditions maintaining product purity and hygiene. Agitated Nutsche Filters are extensively used in Herbal products, Chemical product development, kilo lab operation, pharmaceutical manufacturing, agro chemical and the food industry.

GENERAL DESCRIPTION

A typical unit consists of a dish shape vessel with a perforated plate. The entire vessel can be kept at the desired temperature by using a mixer / agitator and jacket. It's completely leak-proof for vacuum or pressure service. The base plate is having arrangement of bolting bar to hold the filter cloth. Suitable nozzles can be provided including Manhole and Side discharge nozzle. PTFE Lined Stirrers are used for Agitator shaft and solid PTFE blades are used to take high torque generation during solid discharge and re-slurring operation. Drive assembly consist of Motor with VFD, Mechanical Seal is provided for vacuum application. Borosilicate Glass Vessel with different nozzles, Manual/Hydraulic system is provided for movement of agitator as well as bottom plate. PTFE Filter Support Plate.

PROCESS STEPS OF AGITATED NUTSCHE FILTER WITH AGITATOR:

- 1) Filtration.
- 2) Washing of Filter cake.
- 3) Repeat mix or washing of the cake.
- 4) Convection drying of the cake.
- 5) Smoothing with compression of the cake
- 6) Discharge of the wet or dried cake.

ADVANTAGES OF GLASS NUTSCHE FILTER

- G Vacuum filtration possible.
- G Glass being transparent, offers visibility of processes.
- G Inert gas atmosphere can be maintained.
- G Minimal contamination of the cake.
- G Very high solvent recovery.
- G Solvents are closed systems, so no toxic vapors are let off in the atmosphere.
- G Personal safety is maintained, and heat transfer surfaces can be provided to maintain filtration temperature.

SSGPL offer Glass ANF from 2 L to 300 L for Kilo Lab Operations with and without jacket , with and without stirrer.



Cat. Ref.	Working Vol (ltr)	Filter area (m2)	Vessel Dia	Vessel height	Moter Capacity HP
ANFD10	10	0.03	225	300	0.25/0.5
ANFD20	20	0.06	360	325	0.5
ANFD50	50	0.12	400	450	0.5
ANFD100	100	0.16	450	700	0.5
ANFD200	200	0.31	600	775	1
ANFD300	300	0.31	600	1150	1

STANDARD UNITS

HCL ADIABATIC ABSORPTION

Hcl absorption columns are used for absorption of Hydrochloric gas, which statutorily are not permitted to vent in to the atmosphere, and to produce the HCl acid. The column is constructed with a series of packed sections, a gas introduction point below that, a condenser on the top, and a cooler at the bottom. Make water is sprayed from the top and acid is collected from the bottom.

HCl absorption column are available in 80DN to 300DN diameter (for the gas rate 10Kgs/hr to 300Kg/hr approx..)

Unit Cat. Ref.	Packed Column	Condenser HTA M ²	HCl Gas Rate
HCL3	80mm x 3mtr.	0.35 x 2	10 Kg / Hr.
HCL4	100mm x 4mtr.	0.5 x 2	20 Kg / Hr.
HCL6	150mm x 4mtr.	1.5 x 2	60 Kg / Hr.
HCL9	225mm x 4.5mtr.	2.5 x 2	150 Kg / Hr.
HCL12	300mm x 4.5mtr.	4.0 x 2	300 Kg / Hr

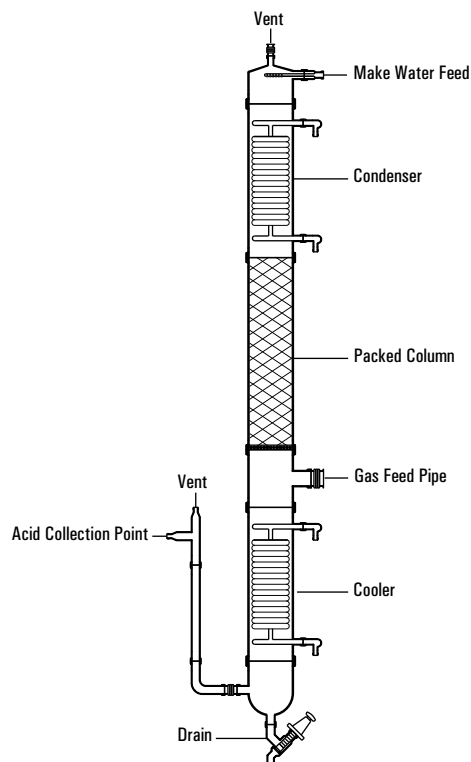

LAB GLASS REACTOR

We have a variety of vessel option to choose from our standard range. Beside the manufacturing of our Standard Vessels / Reactors, we specialize in producing reactors as per customer's requirement.

Reactor Options: Single Wall, Double wall or Triple Wall Glass Reactor

Operating Conditions :-

Temperature: -50°C up to 180 °C

Pressure : Full vacuum up to 0.5 bar

Capacities : 100 ml L up to 10 L

Salient Features

- G Glass Reactors made from Germany Raw Material.
- G Lab Reactor system suitable for most benchtop fume hoods.
- G Stirrer with suitable mechanical seal/stuffing box/magnetic seal.
- G Skid Mounted and quick release clamp for easy installation & removable of glassware.
- G Suitable for vacuum condition
- G Flush bottom with minimum dead volume.
- G Overhead Stirrer geared motor with built-in speed controller & display.
- G Measurement Marking on the vessel.
- G Interchangeable Stirrer anchor, propeller, turbine Digital temperature indicator.

Optional

Hot water/oil circulator, Chiller, heating /Cooling system ,Vacuum Pump, PH probe with transmitter, Pressure Gauge.

Unit Cat.Ref.	Reactor Cap(L)	Gear Motor with Inbuilt Digital Indicator	Addition Funnel	Condenser Length	L x B x H
LJR 1L	1 Ltr. (100DN)	Speed 40 - 400 RPM	250ml	200mm	250 x 250 x 900
LJR 2L	2 Ltr. (100DN)	Speed 40 - 400 RPM	500ml	300mm	250 x 250 x 1350
LJR 3L	3 Ltr. (100DN)	Speed 40 - 400 RPM	500ml	400mm	250 x 250 x 1450
LJR 5L	5 Ltr. (150DN)	Speed 40 - 400 RPM	1000ml	500mm	350 x 350 x 1450
LJR 10L	10 Ltr. (200DN)	Speed 40 - 400 RPM	2000ml	600mm	400 x 400 x 1700

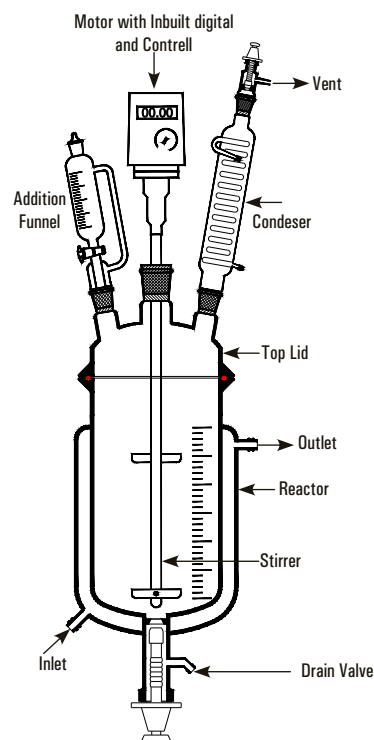

TECHNICAL PACKAGES



We form a combination of Chemical Engineers in the field of Process engineering and its application in the glass equipments/process packages.

DESIGN AND SUPPLY OF VARIOUS

UNITS as per client's requirement are as under:

1. Absorption systems for gases such as HCl, Cl₂, SO₂, HBr, NH₃, Br₂, NO_x etc.
2. Anhydrous HCl Gas Generation Unit by different routes viz.
 - Sulphuric Acid Route - Boiling Route
 - Calcium Chloride Route - Cyclic Route
3. HBr Gas Generator (By Boiling Route)
4. Sulphuric Acid Dilution Units.
5. Hypochlorite Manufacturing Units
6. MCA Condensation Assembly
7. Distillation - Conversion of Batch Process to Continuous Process.
8. Solvent Recovery
9. Iodine Recovery
10. Raw DCB Plant.

KNOW-HOW WITH PLANT

for the following products :

1. Bromine recovery from industrial waste / salt bittern.
2. Nitric Acid Concentration
3. Sodium Hypochlorite

TROUBLE SHOOTING

in above units as well as client's existing plant.

TECHNICAL PACKAGES

WIPING FILM EVAPORATOR

Introduction

Heat sensitive products like vitamins, hormones, enzymes or aromatic substances get adversely affected by way of material degradation due to higher temperature and residence time. This can be avoided if the reactions are carried under vacuum which allows the working temperature to be lowered, and by forming a thin film to reduce residence time, especially in case of liquids of high viscosity, or low thermal conductivity.

For these, Introduces a specially designed range of Evaporators made of Borosilicate Glass. The range varies from laboratory size (80DN) to production plants (300DN).

Construction

The core of the unit is a rotating, fully corrosion resistant wiper system. This has four rows of PTFE wipers. These rows of wipers are divided into vertical segments and each wiper is mounted between two glass rods.

A liquid distributor is located above the wipers. It distributes the medium, fed in through the feed pipe uniformly around the circumference of the evaporator before the medium is finally picked up by the wiper system itself.

The Evaporator has a vapour outlet which can be connected to a descending coil condenser and a receiver.

The drive used for the wiper system is a standard geared-motor with an AC speed regulator. The wiper shaft is sealed by means of a mechanical seal. The evaporator body is constructed as a jacketed pipe. For heating, thermic fluid upto 150 C can be circulated in the jacket.

The unit is designated by the jacketed pipe size. And the capacity of the unit depends on the evaporation rate which in turn depends on the HTA available, the type of heating media, and the evaporation environment i.e. vacuum conditions.

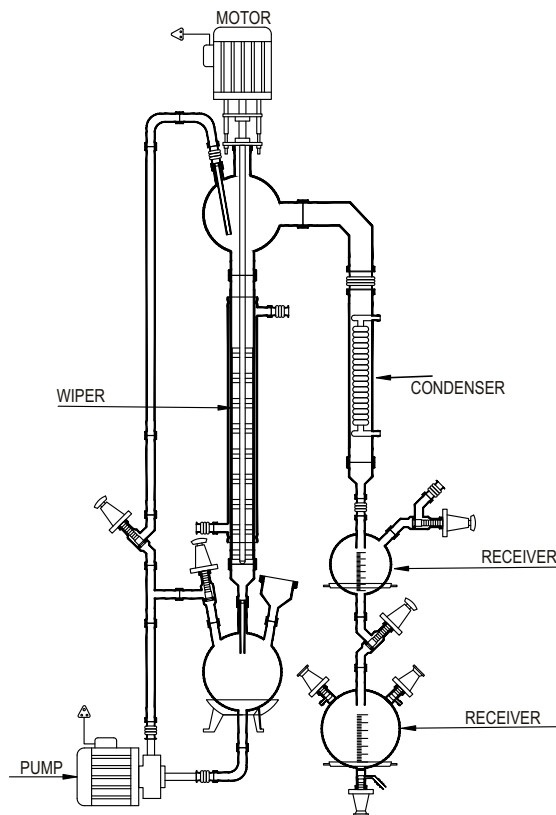

Model	Size DN (mm)	HTA (M ²)
WFE3	80	0.35
WFE4	100	0.47
WFE6	150	0.70
WFE9	225	1.06
WFE12	300	1.41

TECHNICAL PACKAGES

FALLING FILM ABSORBER

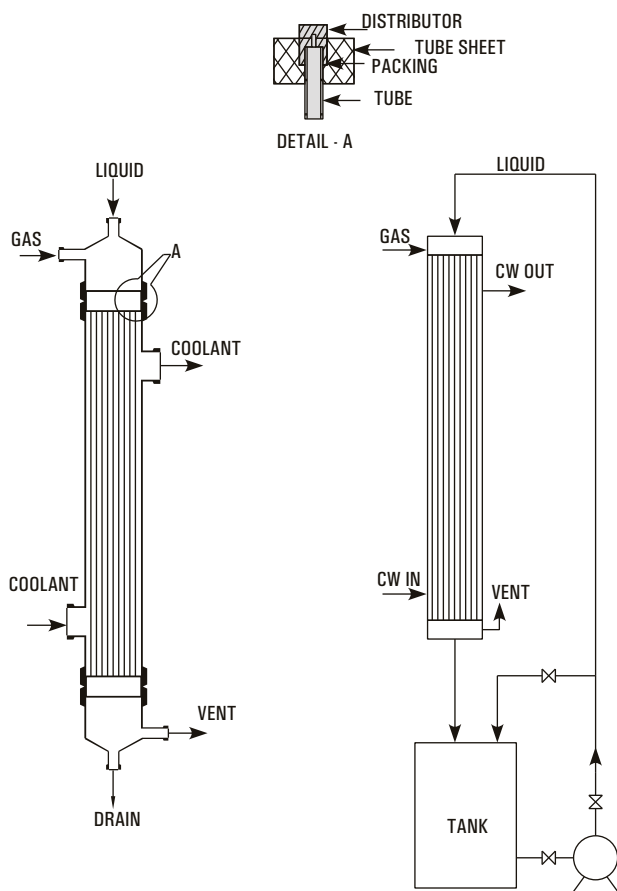

Efficient gas absorption depends on the following :

1. Intimate contact. 2. Efficient Heat Transfer.

This is achieved in a Falling Film Absorber which is essentially a shell & tube heat exchanger in which both gas to be absorbed and absorbing liquid flow co-currently downward with extraction of heat by circulation of coolant in the shell. The absorbing liquid is circulated through a tank till desired concentration is achieved. The liquid flows at such a rate that the tubes do not flow full of the liquid but instead, descends by gravity along the inner walls of the tubes as a thin film. Obviously, this produces a much greater linear velocity for a given rate flow than could be obtained if the tube flowed full.

The equipment works as a number of water cooled wetted-wall columns in parallel and each tube is provided with distribution system on top to effect uniform distribution of both liquid and gas and also formation of a thin liquid film on the inner surface of the tube.

SALIENT FEATURES

1. The heat of absorption is continuously removed. This ensures better absorption and product concentration as compared with conventional packed tower.
2. Low residence time and operating temperature ideally suited to heat sensitive materials.
3. Borosilicate glass and PTFE contact parts ensure corrosion/contamination free operation.
4. Both standard and custom built units are available.
5. Capable of operating from zero to maximum gas flow rate.
6. Ease of installation due to light weight.
7. Trouble free and consistent performance with minimal attention.
8. Wide application e.g. HCl, HBr, NH₃, SO₂, H₂S, Br₂ etc.
9. Less cost.
10. Negligible pressure drop compared to conventional columns.
11. Compact design Sleek and slender.
12. Both heat and mass transfer operations are incorporated in a single equipment.
13. Very high heat transfer coefficient as the liquid falls instead of flowing.
14. Scaling of process fluid is minimal due to high velocity and ease of cleaning by simple acid circulation.
15. Hot conditions are eliminated at all stages namely pipe, tanks and pumps etc.

LIMITATIONS

1. Not recommended for gases containing high proportion of inert (insoluble).
2. Not applicable if the gases are not highly soluble.

SPECIFICATIONS

Sr. No.	Nominal Size (mm)	Absorber Area (m ²)	No. of Tubes/ Tube OD (mm)	Max. Gas Absorption Rate (Pure HCl) * (kg/hr)	Max. Acid Prod. Rate (As 30 % HCl) (kg/hr) *	Height (m)
1.	80	1.00	4/ 20	30	100	4400
2.	100	1.76	7/ 20	60	200	4500
3.	150	4.80	19/ 20	150	500	4600
4.	225	7.80	31/ 20	250	833	4920
5.	300	15.30	61/ 20	500	1667	5050
6.	400	36.00	143/ 20	1175	3917	5300
7.	450	47.00	187/ 20	1500	5000	5700
8.	600	84.00	333/ 20	2700	9000	5800

TECHNICAL PACKAGES

SULPHURIC ACID CONCENTRATION SYSTEM

Commercial sulfuric acid is a cheap commodity and in its dilute and impure form does not have good market potential.

Disposal by neutralization with lime is associated with, problems of solid (calcium sulfate) handling and also adds to the cost.

To overcome these problems know-how, design engineering services of sulfuric acid concentration system in which the dilute sulfuric acid generated is reconcentrated to desired level for reuse. That is to say a twofold benefit of eliminating the disposal problem and minimizing fresh commercial acid requirement.

PROCESS DESCRIPTION

The process is extremely simple & involves concentration of dilute sulfuric acid by evaporation using steam/thermic fluid as heating media under vacuum. The dilute feed is preheated & fed to a series of evaporators in stages to achieve the concentration level. The vapors from the evaporators are condensed and drained out through barometric legs and non-condensables are removed by an ejector. The final product is cooled and drawn in the storage tank.

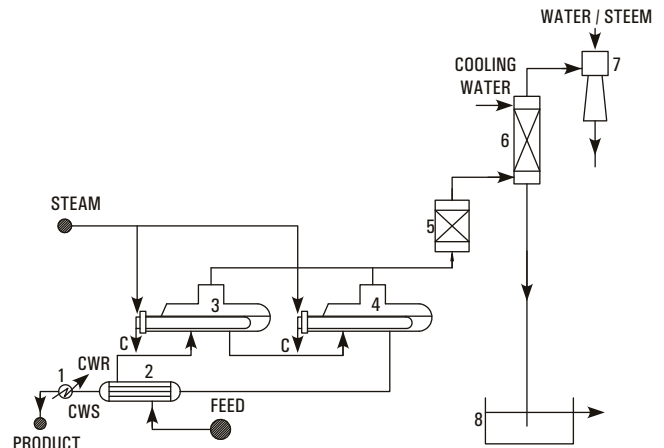

TWO STAGE SULFURIC ACID CONCENTRATION SYSTEM

KEY

- 1 - PRODUCT COOLER
- 2 - FEED PREHEATER
- 3 - 1ST, STAGE EVAPORATOR
- 4 - 2ND, STAGE EVAPORATOR
- 5 - MIST ELIMINATOR
- 6 - DIRECT COOLER
- 7 - EJECTION
- 8 - SEAL POT
- C - STEAM CONDENSATE
- CWS - COOLING WATER SUPPLY
- CWR - COOLING WATER RETURN

REQUIREMENT OF UTILITIES

The requirement of utilities viz. steam/thermic fluid, cooling water and power vary widely depending on feed rate, feed concentration and product concentration. For example for a plant having 50TPD feed containing 50% H₂SO₄ the consumption of utilities for achieving 70% concentration are given below.

- | | |
|------------------------------|------------|
| 1. Steam @ 6 bar(g) pressure | 800 Kg/hr |
| 2. Cooling water @ 30 °C | 70 Cu M/hr |
| 3. Power | 15 KW |

BROMINE RECOVERY SYSTEM

Bromine is available in the sea bittern, as well as Industrial waste e.g. Aq. HBr / Aq. NaBr / Aq. KBr. The Bromine concentration in the feedstock varies from 2 gpl to 300 gpl from industry to industry.

SSGPL Offer suitable bromine recovery plant for the various feedstock based on his 20 years expertise in this field. Suggest cold process for bromine concentration below 3 gpl and Hot process above 3 gpl.

The package considered is schematically shown in drawing enclosed herewith.

The process consists of simultaneous chlorination & steam blowing. The feed stock acidic in nature is preheated to near its boiling in feed pre heater and then fed to the main column where steam and chlorine are blown simultaneously. The bromine as set free by chlorine are steam distilled. The liberated bromine together with steam and some excess chlorine is condensed in the condenser. The condensate is taken to a gravity separator where bromine and bromine water are separated. While bromine is taken in the purification column the aq. layer is recycled into the main column. Crude bromine is purified under reflux and pure bromine is collected in the receiver. All uncondensed vapour pass through the tail scrubber to recover the last traces of bromine.

Sr.	DESCRIPTION
1.	TAIL SCRUBBER
2.	FEED PREHEATER
3.	Br ₂ STRIPPING COLUMN
4.	Br ₂ CONDENSERS
5.	PHASE SEPERATOR
6.	CRUDE Br ₂ RECEIVING VESSEL

7.	REBOILER
8.	PURIFICATION COLUMN
9.	PRODUCT COOLER
10.	PRODUCT COOLER
11.	VENT CONDENSER
12.	PRODUCT RECEIVER VESSEL
13.	PRODUCT COOLER

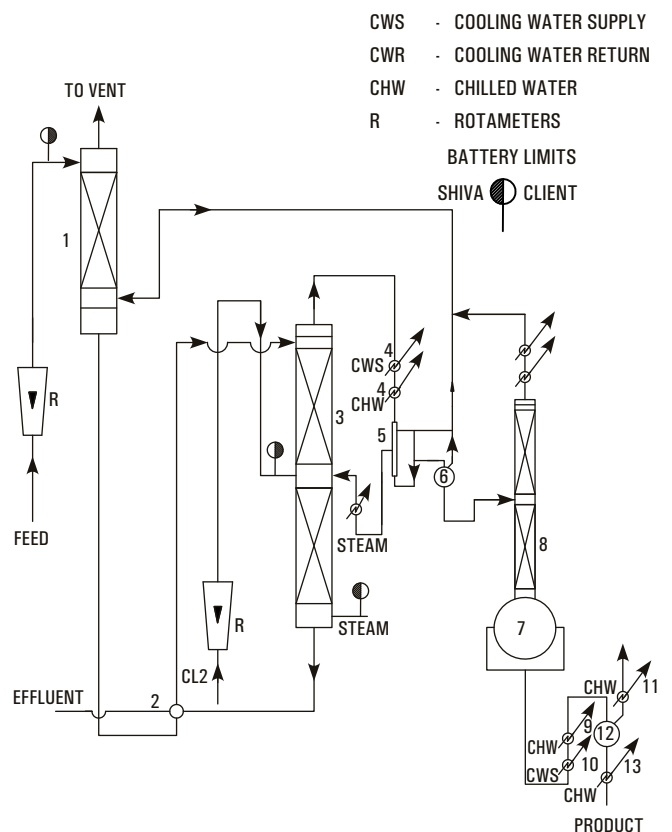

- CWS - COOLING WATER SUPPLY
- CWR - COOLING WATER RETURN
- CHW - CHILLED WATER
- R - ROTAMETERS
- BATTERY LIMITS
- SHIVA CLIENT

TECHNICAL PACKAGES

ANHYDROUS HCL GAS GENERATOR

Commercial Hydrochloric Acid is available in the market as 30% aqueous solution. But for certain applications e.g. bulk drug and pharmaceuticals, HCl is required in anhydrous state for critical reactions where moisture cannot be tolerated. Such users generate anhydrous HCl from commercial grade for their captive consumption.

METHOD

Several methods have been adopted by industries. But generation by Sulphuric Acid Route and Boiling Route are commonly practiced.

We offer Calcium Chloride Route also.

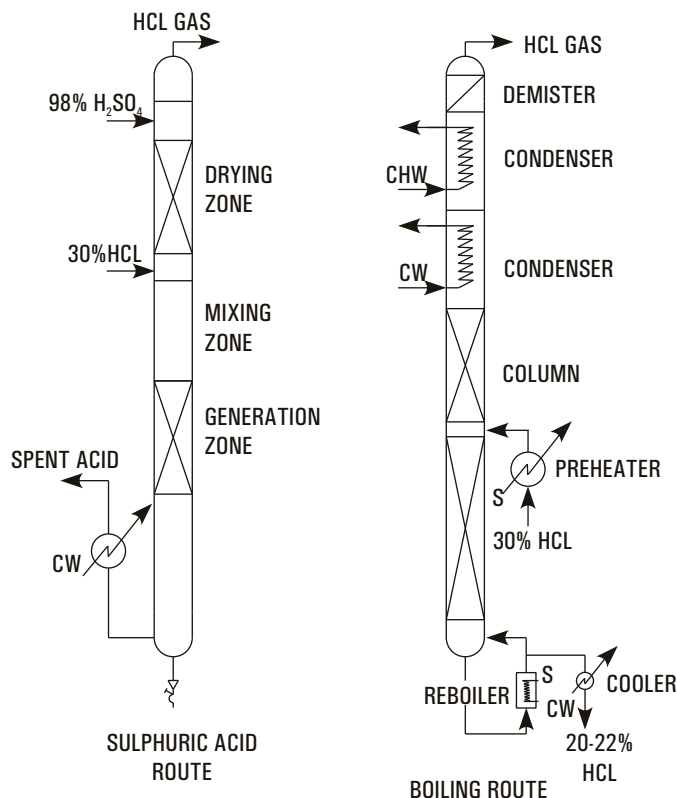

Route	Sulphuric Acid Route	Boiling Route
Working Principle	Hydrochloric acid is highly soluble in water but the solubility diminishes in presence of H ₂ SO ₄ and at 70 to 75% H ₂ SO ₄ concentration its solubility is negligible. Thus by adding (98%) commercial Sulphuric acid to commercial hydrochloric acid (30%) in proper ratio the entire HCl can be liberated in gaseous form leaving 75% H ₂ SO ₄ as spent acid.	Aqueous hydrochloric acid forms a maximum boiling point azeotrope at 110°C containing 20.24% HCl at atmospheric pressure. Thus by distilling commercial hydrochloric acid (30%) pure HCl gas can be generated and spent acid will contain over 20.24% HCl.
Process Outline	Metered quantities of commercial sulphuric acid hydrochloric acids are fed to the unit where they mix in the Mixing Zone. The gas generated forms a froth and enters the Generation Zone where while traveling through a bed gas is released which travels upwards through the Drying Zone. Here the gas comes in intimate contact with downward flow of 98% H ₂ SO ₄ . The dry gas leaving the unit passes through a rotameter. The spent liquor containing 70-75% H ₂ SO ₄ passes through the Cooling Zone before being discharged.	Metered quantity of commercial hydrochloric acid is preheated in a preheater by steam and fed to a fractionating column with steam as heating media in the reboiler. The vapours leaving the column are condensed with coolant as cooling water and chilled brine in stages. The relatively dry gas passes through a mist eliminator and then through a rotameter. The spent acid containing 22% HCl is cooled through a cooler and then discharged.
Salient Features	<ul style="list-style-type: none"> - Operational reliability the unit can be started/ stopped in seconds. - Available in wide range of capacities from 5 to 200 kg/hr of dry HCl. - Except cooling water no other utility e.g. steam chilled water etc. required. - Anhydrous gas. - Capable of operating from 25 to 120%. - Ease of installation. - Negligible pressure drop. - High efficiency 99%. 	<ul style="list-style-type: none"> - Operational reliability. - Available in wide range capacities from 5 kg/hr to 200 kg/hr of dry HCl. - Except commercial hydrochloric acid, no other raw-material is required. - Anhydrous gas. - Capable of operating from 25-100%. - Ease of installation. - Negligible pressure drop.
Indicative Raw-material & Utilities for 20 kg/hr HCl	30% HCl - 70 kg/hr 98% H ₂ SO ₄ - 170 kg/hr Cooling Water - 2 m ³ /hr	30% HCl - 200 Kg/hr Saturated Steam - 50 kg/hr Cooling Water - 3.5 m ³ /hr Chilled Brine - 4 m ³ /hr

TECHNICAL PACKAGES

ANHYDROUS HCl GAS GENERATOR - CALCIUM CHLORIDE ROUTE

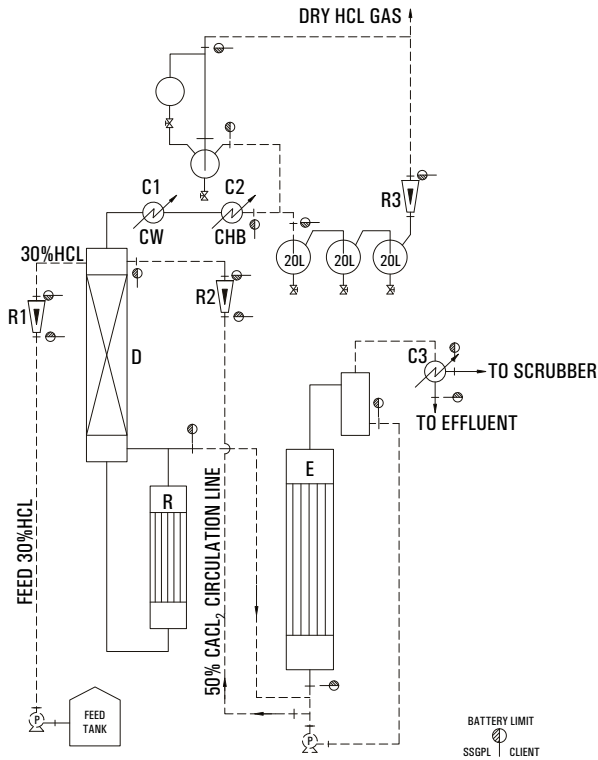

Working Principle:

Hydrochloric acid and water form a maximum boiling point azeotrope at 110°C corresponding to a concentration of 20.24%; (w/w) HCl. By adding concentrated CaCl₂ solution to commercial hydrochloric acid the azeotrope point is eliminated and the entire HCl becomes available for liberation by distillation. Anhydrous HCl gas generation through Calcium Chloride Route is the most environmental friendly technique.

Process Description:

The above principle- is achieved in practice by feeding metered quantities of commercial HCl and 50% CaCl₂-solution to a stripping column with a steam heated re-boiler at bottom. The effluent from bottom of the column is a dilute acidic calcium chloride solution which is concentrated to 50% in an evaporator and re-used. The vapor leaving is condensed stage wise with cooling water and chilled brine as coolant. The relatively dry gas passes through a mist eliminator and then through a rotameter to the point of consumption.

Raw material utility requirements:

The indicative requirements for 20 Kg/hr HCl gas generator are given below.

1. 30-32 % HCl, (Kg/hr) : 66
2. Cooling water at 30 °C (M³/hr) : 4
3. Chilled brine at -10 °C (M³/hr) : 3
4. Steam at 6 Kg/cm² (g) : 150

LEGEND

R - REBOILER

D - COLUMN

E - EVAPORATOR

C1 - PRIMARY CONDENSER

LEGEND

C2 - SECONDARY CONDENSER

R1 - FEED HCL ROTAMETER

R2 - FEED CaCl₂ ROTAMETER

R3 - DRY HCL GAS ROTAMETER

LEGEND

CW - COOLING WATER

CHB - CHILLED BRINE

C3 - CONDENSER

P - PUMP

CONTINUOUS DISTILLATION SYSTEM

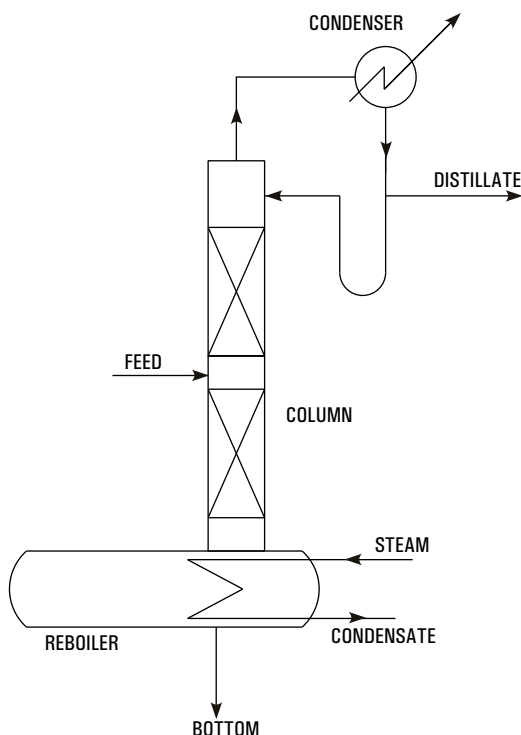

The limitations of batch distillations are naturally circumvented in continuous distillation as shown in fig.2 which is a typical fractionating unit comprising of ratification &stripping sections. Here feed is continuously fed to the column with withdrawal of top & bottom products. The process takes care on its own by simply maintaining the flow rates of feed & utilities.

However when more than two products are desired as in case of multi component systems additional columns are required as each column is capable of giving two products only. That is to say, for multi component system only one product is obtain in relatively pure form from each column. The other product containing the remaining components is fed to a subsequent column where again one product is obtained in relatively pure form. The addition of columns continue till the system becomes binary & both components are separated in the final column.

An important principle to be emphasized is that a total n-1 fractionators are required for complete separation of system of n components. Which of the two products in a column is to be obtained in relatively pure form depends on relative volatility of each component in the feed stock. For example consider a ternary solution consisting of a components A, B & C whose relative volatilities are in that order (A most volatile). In order to obtain three substances in substantially pure form either of the schemes shown in fig-3 may be used. Which of the two schemes would be used depends on the relative difficulties of separation in each method and the choice calls for finer considerations of principles of distillation. However scheme (b) is usually preferred since it requires one vaporization of substance A.

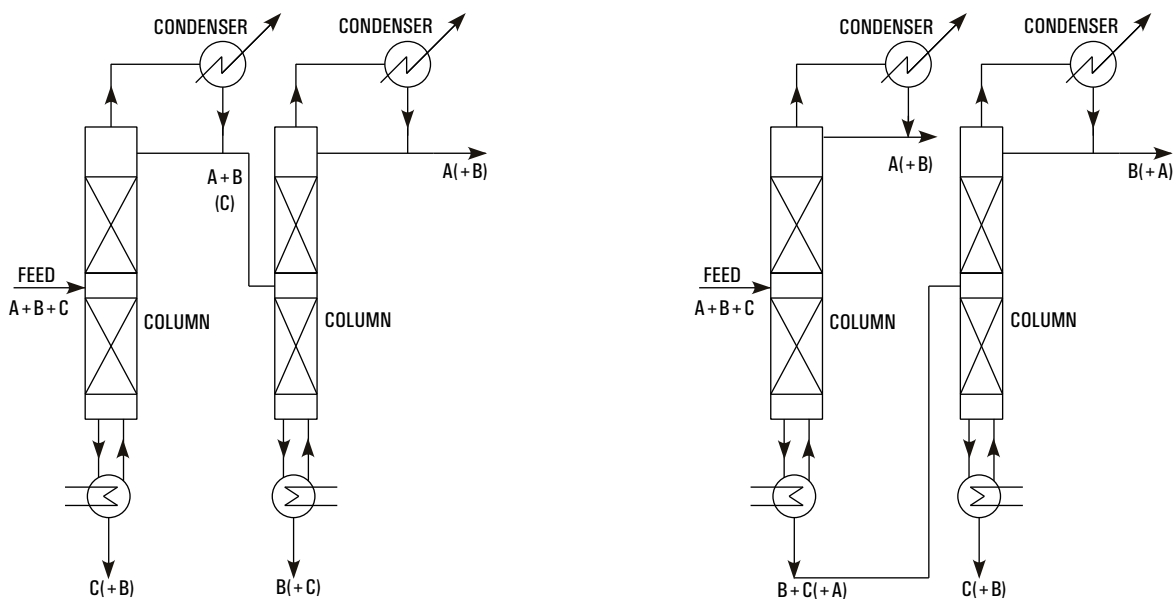

Component given in bracket are in small quantities.

SOLVENT RECOVERY

Solvents are universally used in wide variety of industries, their use by no means being limited to the chemical industry. The choice of solvents such as xylene, acetone, butyl acetate, methanol etc. depends on the type of application and economical considerations.

In many cases, the solvent - after use - is contaminated and not in a reusable condition. Purchase of fresh solvent and disposal costs of the contaminated solvent can prove expensive operations. Therefore, it makes sound economic sense to investigate the recovery of contaminated solvents for re-use.

Design and supply solvent recovery plants which are capable of recovering solvents from a few kg/day to many tons/day.

Applications:

1. Solvent Recovery Units are carefully designed to cater the specific requirement for each duty for wide range of solvents.
2. Continuous Distillation Units have distinct advantages, such as
 - 2.1. Ease of Operation due to steady state working.
 - 2.2. Economical design as each equipment viz. column, condenser reboiler is designed for uniform and steady-load.
 - 2.3. Uniform product quality,
 - 2.4. Uniform & low consumption of utilities.
 - 2.5. Higher productivity as down time for start-up, emptying etc. is eliminated.

The outline flow-sheet of the plan is shown in Figure. Regulated quantity of feed is fed to a distillation column from an overhead vessel. The overhead vessel is provided with a vent condenser with chilled water circulation to arrest loss of acetone vapor. The reboiler at the bottom of column in this case was a steam heated oil-bath. The vapors from top of the column pass through primary and secondary condensers with cooling water and chilled water circulation. The condensate is partially refluxed and balance continuously drawn out and collected in receiver provided with a vent condenser. The residue from the reboiler is continuously drained out.

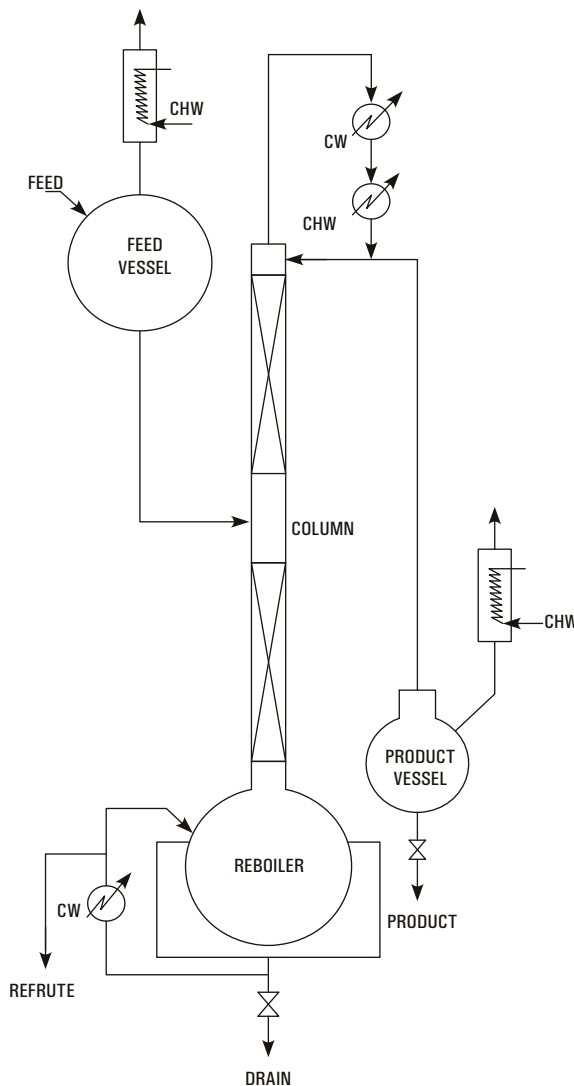

TECHNICAL PACKAGES

ROTATING DISC EXTRACTION COLUMN

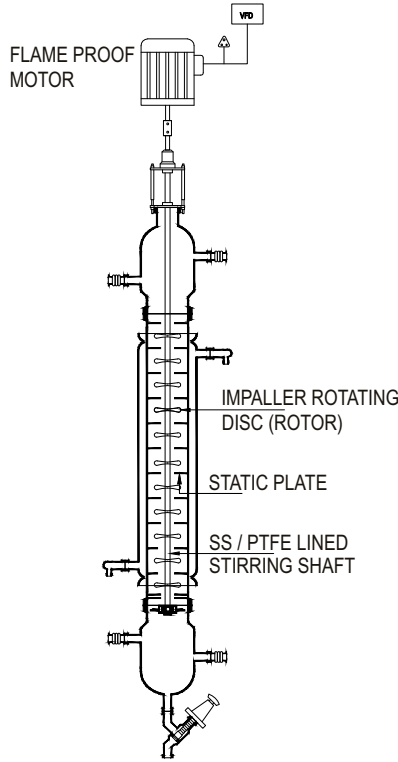

Introduction

Separation will be carried out normally with the help of distillation but when it is not feasible by distillation or ineffective liquid-liquid extraction is one of the process to consider. There few mixtures are having close boiling points components or heat sensitive components which can not withstand the temperature of distillation, even under vacuum may often be separated from impurities by extraction which utilize the chemical properties like specific gravity, solubility etc. instead of vapour pressure differences.

Separations by liquid-liquid extraction can be defined as the selective removal of one or more components either from a homogenous liquid mixture or from a solution, using a second liquid or solvent, which is partially or wholly immiscible with the first.

Construction

The core of the unit is a rotating disc with varied no of stages between 1 m to 2 m height. The RDC blade can be made of PTFE or SS 304 or SS 316 depending on the customer requirement.

The system can be supplied with or without dosing pump and two feed vessels as well as two receivers. The drive used for the rotation of the disc is a standard geared-motor with an AC speed regulator. The agitator shaft is sealed by means of a mechanical seal.

The outer column can be constructed as a jacketed pipe or without jacket as per the customer requirement. The unit is designated by the diameter of the extraction column and no. of stages as per the customer specification depends on the flow rates and properties of the chemical used.

Model	Size	DN (mm)Hight
RDC3	80	2.0
RDC4	100	2.0
RDC6	150	2.0
RDC9	225	2.0
RDC12	300	2.0
RDC16	400	2.0

PRECIOUS METAL REFINING

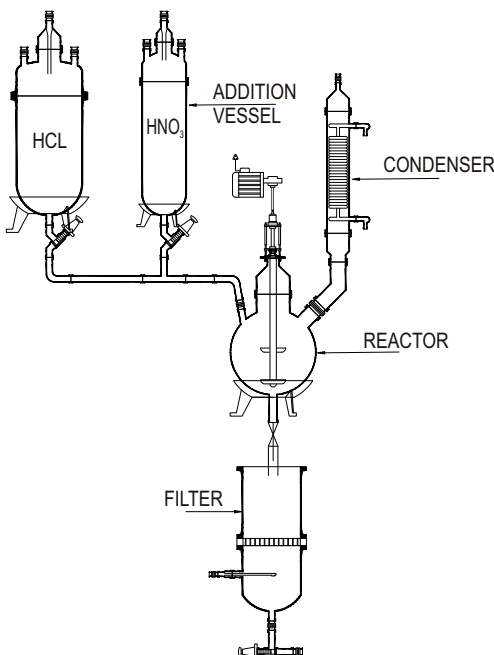

Borosilicate glass is inert to almost all materials. Due to which it is now widely used in Precious Metal Refining Industry. Borosilicate Glass is the only material which doesn't absorb precious metals. Its transparency allows ease of visualization & smooth surface allows ease of cleaning.

We have supplied various capacity glass assemblies in precious metal refinery for Aqua Regia solution. Our Glass Container/Vessel are also used as dissolution, precipitator and separator for Gold /silver/ platinum recovery with Aqua Regia / Hydrazine solution.

Scrubbing Unit :The fumes generated by Aqua Regia in a gold refining process are toxic. We design & offer suitable capacity Glass Scrubber Unit for removal of NOX Fumes.

Filer Unit :We also offer Glass Filter Unit on wheels for removing of precious metal from the Aqua Regia solution.

Nitric Acid Boiling Apparatus :Nitric Acid Boiling Apparatus with condenser for Laboratory testing is also available with us.

Sampling Tubes :Vacuum Tubes (VPT 111) for removal of samples from the batch are also manufactured by us.

TECHNICAL PACKAGES

NITRIC ACID PURIFICATION SYSTEM

The process to purify industrial/technical grade nitric acid involves a single stage distillation to leave non-volatile impurities in the still bottoms. 69% – 70% concentrated nitric fluid is delivered by means of a metering pump from a storage tank into the glass still which is equipped with Electrically heated Oil Bath. The acid vapors flow through a mist removing packed section to the Glass condenser. Depending on the desired concentration high pure water can be added as a diluent to the condensed product before entering the bleach column. Clean air is introduced at the base of the bleacher. Air and oxides of nitrogen are vented through a condenser to a scrubber. Entrained nitric acid is not returned to the bleaching column but collected separately. Removing of all NOx out of electronic grade nitric acid.

Design Basis & Requirement of Utilities :

Capacity	40	kg/hr
Commercial grade Nitric Acid - 69-70%	44	kg/hr
Electric Heater	48	kw
Cooling Water @ 7 deg. C*	4-5	Cu.M/hr
Space Requirement	3 x 3 x 8 m	

Size Available 5 kg/hr to 500 kg/hr

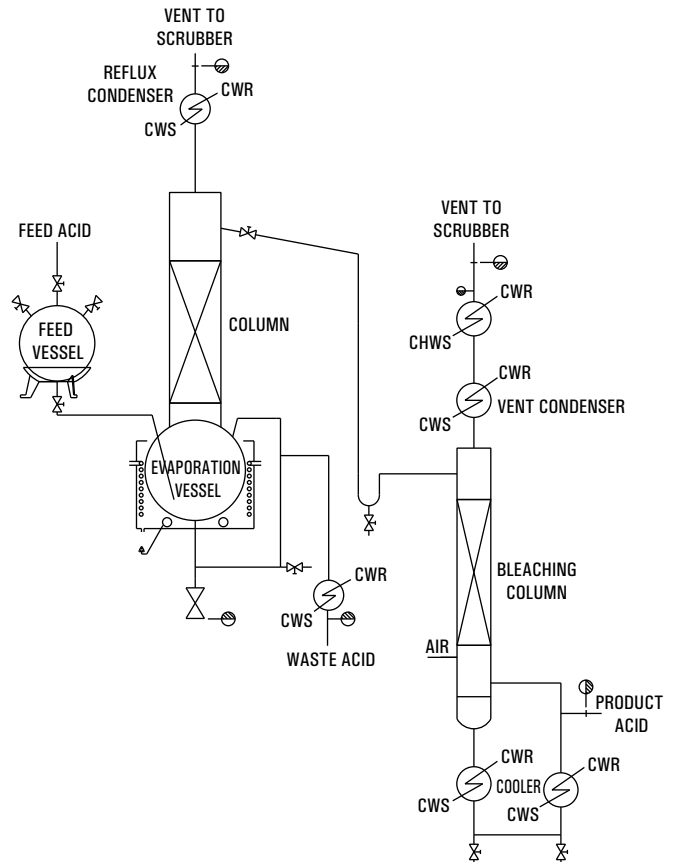

HCL PURIFICATION SYSTEM

Commercial Grade Acid (30% HCL) is feed to the Reboiler through Flow meter. The feed will be heated in Re-Boiler by heating media to evaporate the 20-22% HCL. The 20-22% HCL+ Water Vapour generated will be condensed in Top Cooler with Cooling water & chilled water. The gas leaving the top will be of pure HCL gas will fed to the scrubber wherein it will be scrub further with condensed Azeotropic solution or with fresh process water to make ultrapure HCL.

There are various options to make ultrapure HCL Depending on following factor : 1. feed quality 2. Effluent generation 3. Capital investment etc...

Various solution for HCL purification based on customer need.

Sr. No.	Feed 30% HCl (w/w)	Product 36-37% HCl	Cooling Water @32 deg. C	Chilled Water @8 deg. C	Power
	Kg/hr	Kg/hr	Cu. m. / hr *	Cu. m. / hr *	KWH (Max.)
1	15	12.5	8-10	5-6	10

- ME MIST ELIMINATOR
- R1 ROTAMETER FOR FEED
- R2 ROTAMETER FOR CIRCULATION OF HCL
- R3 ROTAMETER FOR PRODUCT
- CWS COOLING WATER SUPPLY
- CWR COOLING WATER RETURN
- CHWS CHILLED WATER SUPPLY
- CHWR CHILLED WATER RETURN
- P PUMP

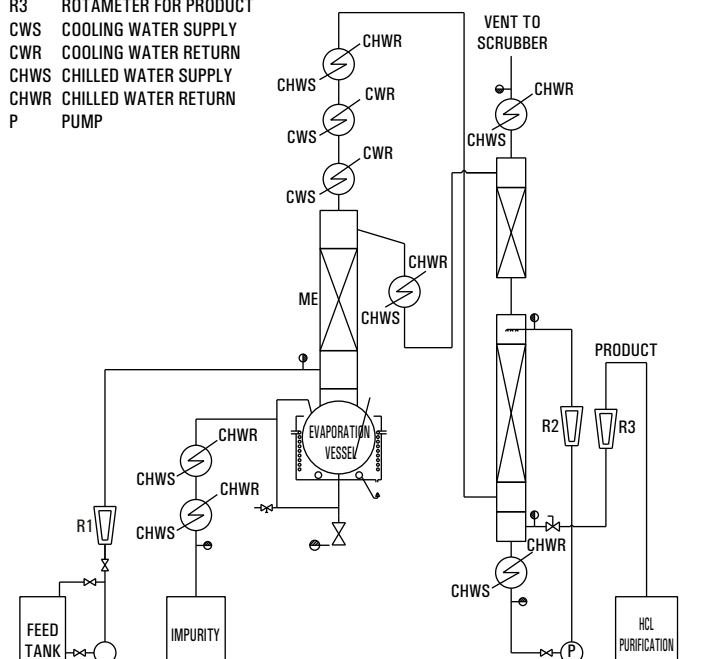

ROTARY FILM EVAPORATOR

2 TO 100 LITERS



INTRODUCTION

Rotary Film Evaporator is essentially a thin film evaporator. The rotating flask continuously covers a large surface area with a thin film which is ideal for rapid heat transfer. Fortuitously, the thin film also ensures uniform heat distribution without local heating. The facility to work the unit under full vacuum further facilitates evaporation at as low temperature as possible. That is to say, both boiling point and residence time are significantly reduced. These features combined, renders rotary film evaporator to be ideally suited for evaporation of heat sensitive material. It is equally successful for evaporation of suspension in crystallization processes, drying of powder/granules etc.

Rota Evaporator finds wide use from small scale laboratory set-ups to industrial operation. Rotary Film Evaporator is preferred by both research and production facilities and has been used by laboratory and chemical, pharmaceutical and biotechnological industries.

ROTARY FILM EVAPORATOR

5 TO 100 LITERS

SALIENT FEATURES

1. Universal corrosion resistance.
2. Auto controlled digital display of rotational speed and bath temperature.
3. Digital display of process time.
4. Automatic bath lifting.
5. Automatic bath lowering in case of power failure.
6. Withstands full vacuum.
7. Ideally suited for heat sensitive material.
8. Maintenance free working - Operational reliability.
9. Available in large sizes upto 400 Litre.

CONSTRUCTION

Rotary Film Evaporators are completely self-contained units consisting mainly of:

G An electrically heated SS heating bath with facility for raising and lowering the height.

G Rotating flask of corrosion resistant borosilicate glass which is connected to drive by a coupling.

G The drive is a hollow GFT glass shaft which also acts as vapor off-take pipe. The drive shaft is sealed on condenser/receiver with Teflon seal. Power is transmitted to the shaft by a motor driven gear with provision for varying speed.

G Condenser/receiver arrangements are of standard design depending on the model/size.

G **Specialty: Mechanical Seal Arrangement and T shaft (Made from GFT) with Ceramic Seal plate which results optimum vacuum Without Breakage.**

PERFORMANCE DATA

The performance of Rota-evaporator depends on various parameters such as temperature differential between bath and contents of flask, RPM, flask capacity and working pressure. An indicative comparison of boil-up of CCl₄ rates for 20L, 50L and 100L is given in adjacent figure

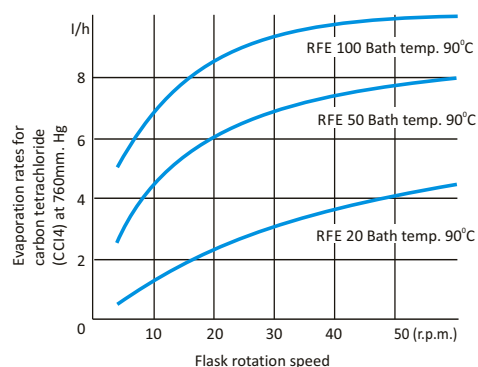

Technical informations related to various models are furnished below :

Model	Rotating Flask Cap. (Ltrs.)	Rotating Speed (rpm)	Electric Motor Rating	Condenser Cooling Area M ²	Receiver Flask Cap. (Ltrs.)	Power Supply (Volt/Hz)	Bath Rating KW
RFE 5	5	20-280	180 Watt	0.2	2	230 V, 50 Hz 1 Phase	2
RFE 20 RFE 10	10	20-135	0.25 HP	0.5	10	415 V, 50 Hz 3 Phase	4
RFE 50	50	20-135	0.50 HP	1.5	20	415 V, 50 Hz 3 Phase	6
RFE 100	100	20-90	1 HP	2.5	50	415 V, 50 Hz 3 Phase	12

ROTARY FILM EVAPORATOR

5 TO 100 LITERS

5, 10, 20, 50, 100 Ltrs.

Salient Features:

- * all RFE can comply GMP And Non GMP norms according to customer requirement.
- * Attractive Vertical Orientation
- * Digital RPM indicator & VFD based speed control.
- * Digital Temperature Indicator & Controller
- * Digital Process Time Indication
- * Digital vapor temperature indicator
- * Motorized VFD based UP & down of bath.
- * S.S. bath with insulated & electrical heaters with overflow nozzle & drain valves.

- * Durable S.S. gearbox cover , with motor encased into the Mechanical Assembly.
- * Complete glass assembly as per the specs in the table
- * Anti-splashing hood
- * In non GMP model body will be M.S. Powder coated.
- * The whole unit is mounted on lockable wheels.*
- * Fully tested & ready to use!!

Optional:

- * Chiller unit
- * PTFE COATED DIAPHRAM / OIL SEALED Vacuum pump with setup

Note:

20 Liter Unit can be supplied with adjustable 10Ltr. Main Flask in 20Ltr. Rotary Film Evaporator so it can be operated at lower volume as and when required.

5 Liter Unit can Accommodate Interchangeable 1, 2, 3, & 5 Liter Flasks. Main flasks will be 5 Liter. So, it can be operated at lower volume as and when required.

Optional Utility Equipment for Rotary Film Evaporator VACUUM PUMP

DIAPHRAGM PUMP (Dry Pump)

Suitable For RFE 5 and 20

DryFast^{eco} is the latest range of the cost effective and chemical resistant diaphragm pump from WELCH Vacuum products.

This two stage diaphragm pump would be an excellent choice for a wide range of laboratory vacuum applications like distillation, drying, concentration, filtration and aspiration etc.

DryFast^{eco} would be your ecological chemical resistant diaphragm pump for various lab-scientific applications. **DryFast^{eco}** can provide turnable vacuum to <8 mbar.

Functional Benefits:

- G Able to support a wide of chemical applications.
- G Uses extra coated layers of PTFE liner for diaphragm, thus making it more robust.
- G Dry running operation, Eco –friendly and low maintenance.
- G Lightweight, durable, most suitable for 24x7 of continuous operation.
- G Equipped with an adjustable control valve, precise settings of the flow and vacuum is easily achieved.

Key applications:

- G 5-20 Liter Rotary Evaporation
- G Vacuum Oven
- G Vacuum Distillation
- G Vacuum Network
- G Vacuum Concentrator
- G Gel Dryer
- G Degassing Desiccation
- G Aspiration
- G Vacuum Filtration

PARAMETER	DRYFAST ECO
Free Air Displacement @50 Hz	33 L/min.
Ultimate Pressure	< 8 mbar
Tubing Needed (ID)	9 mm
Power	230 50/60 Hz
Weight	9 Kg



ROTARY FILM EVAPORATOR

5 TO 100 LITERS



Oil Sealed VACUUM PUMP

These are oil-immersed, Rotary vane type pumps. The rotor, with two spring loaded vanes is mounted eccentric in the stator body, as the rotor rotates, the vanes sweep the crescent shape air space twice in each revolution. There is an in-built non-return valve which prevents backflow of air. Manufactured from graded material/ all moving parts are precisely machined/ ground and assembled with close tolerances. This results in increased efficiency and long trouble free operating life.

Accessories:

- G moisture trap. Inlet dust filter. Vacuum gauge with regulator. trolley for small pumps.
- G Use oil : ENCL-46 (HP) SAE-30 or equivalent, vacuum oil.
- G vacuum measured by McLeod gauge at suction port of the pump.

Applications:

Distillation, dehydration and filtration processes existing electronic tubes, GLS lamps/ mercury vapor lamps and tubes, vacuum methodology, vacuum sublimation, vacuum impregnation, thin film coating, refrigerator and air conditioner servicing.

Rotary Evaporator Model	Vacuum Pump MODEL NO.	No. OF STAGES	FREE AIR DISPLACEMENT		ULTIMATE VACUUM mm of Hg.	DRIVE MOTOR REQD H. P.	APPROX. OIL FILLING Ltrs.
			Lt. / Min.	C.F.M			
RFE 5	HL -50	2	50	1.8	0.005	0.25	2
RFE 20 /RFE 10	HL - 100	2	100	3.5	0.005	0.5	3
RFE 50	HL - 150	2	150	5.3	0.005	1	4
RFE 100	HL - 300	2	300	10.6	0.005	1.5	8

Utility Equipment for Rotary Film Evaporator

CIRCULATING CHILLER WATER BATH

- The Specifications of Chiller Water Bath is as below

Rotary Evaporator Model	Chiller MODEL	Temp. range	Cooling Capacity		KW	Tank Capacity	Process Pump	DRIVE MOTOR REQD H. P.
			Ton of Refrigeration	Kcal/Hour				
RFE 5	FRAC 600	+5°C to +25°C	0.5	1500	1.7	20	35 LPM @ 0.3 Bar	0.25
RFE 20 /RFE 10	FRAC 1000	+5°C to +25°C	1	3000	3.5	40	50 LPM @ 1.2 Bar	0.5
RFE 50	FRAC 2000 3P	+5°C to +25°C	2	6000	7.0	75	50 LPM @ 1.2 Bar	0.5
RFE 100	FRAC 5000	+5°C to +25°C	5	15000	17.5	150	100 LPM	1



LABORATORY GLASSWARE & APPARATUS



- Bottles** : Aspirator Bottles # Dropping Bottles # Mac-cartney Bottles # Regent Bottles # Roux Bottles # Specific Gravity Bottles # Weighing Bottles # Burretes
- Columns** : Chromotography Columns # Fractionating Columns
- Flasks** : Volumetric Flasks # Conical Flasks# Culture Flasks # Filtering Flasks # Flat Bottom Flasks # Reaction Flaks # Round Bottom Flasks
- Funnels** : Dropping Funnels # Pressure Equalizing Funnels # Seperating Funnels
- Condensers** : Liebig # Alliihn # Graham etc.
- Beakers** : Low Form or Toll Form # With or Without Spout
- Extractors** : Solvent Extraction.

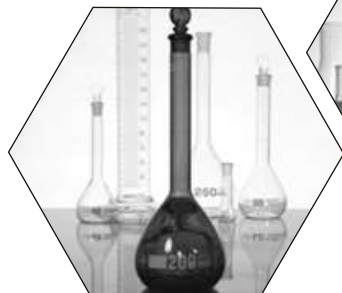

Volumetric Flask



Flask



Bottles



Sintered Glassware



General Glassware

LABORATORY GLASSWARE & APPARATUS

FRACTIONAL DISTILLATION UNIT

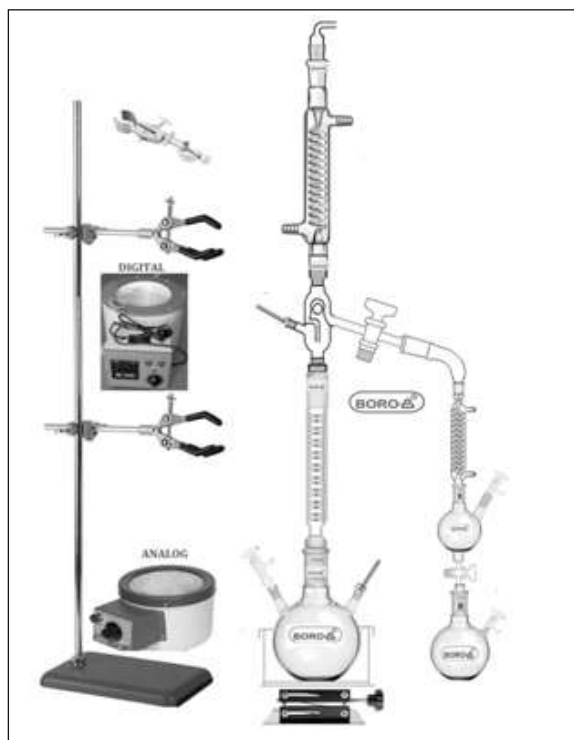

REFLUX REACTION CUM DISTILLATION UNIT

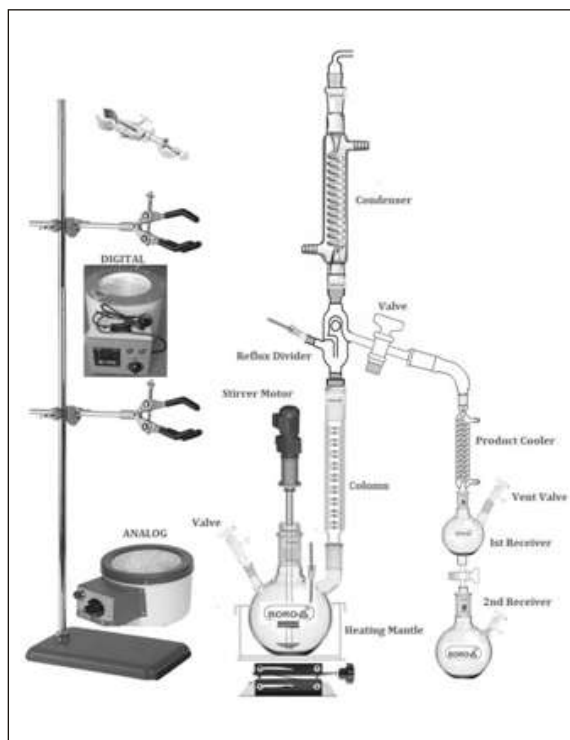

SOXHLET EXTRACTION UNITS

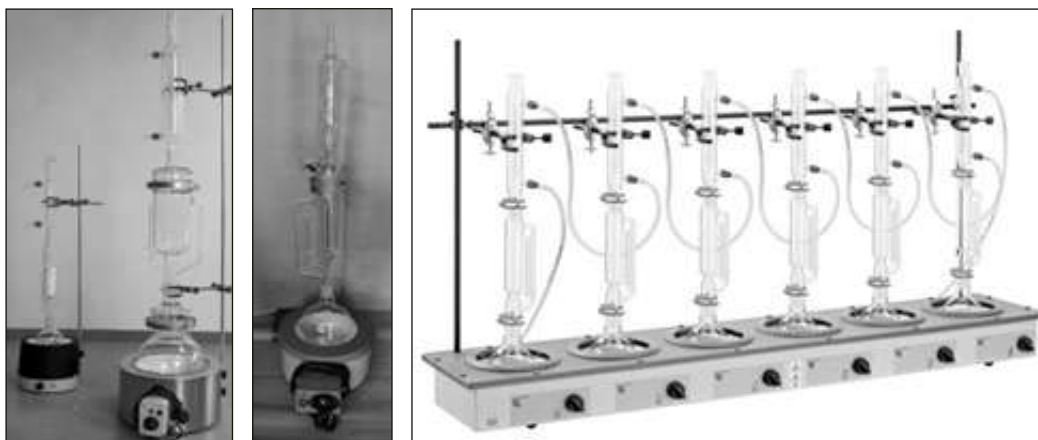

DISTILLATION UNITS

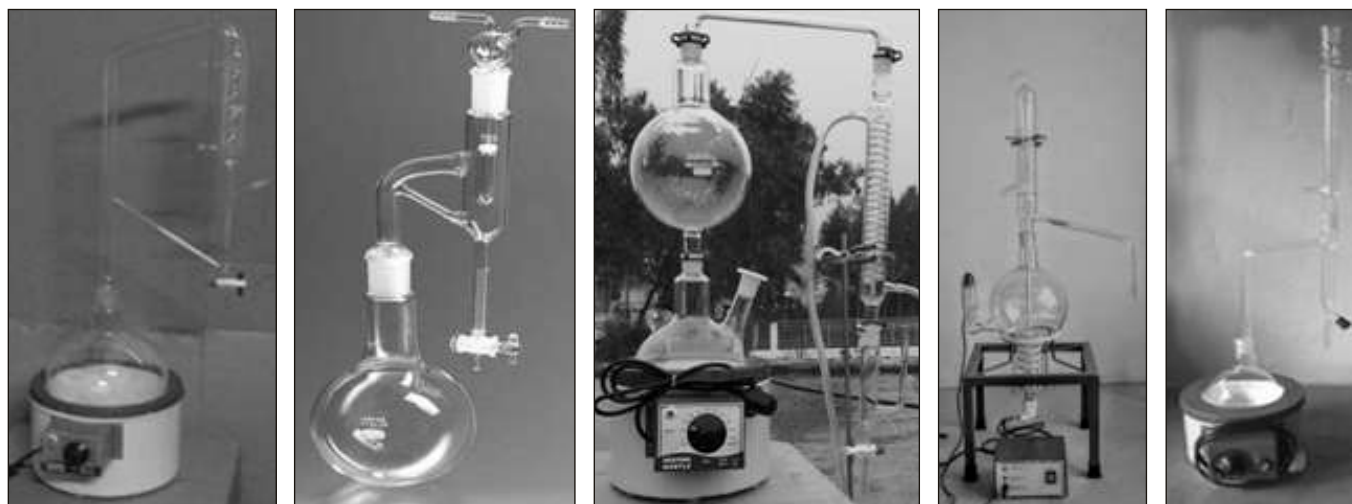

LABORATORY GLASSWARE & APPARATUS



WATER DISTILLATION UNITS

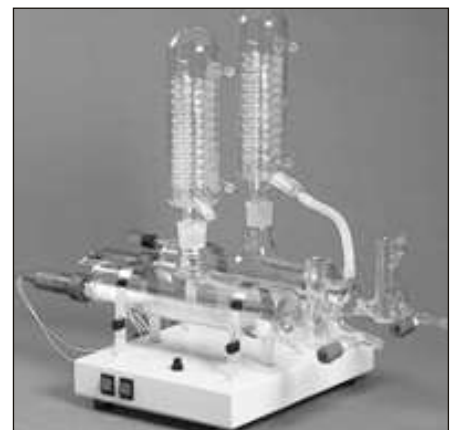
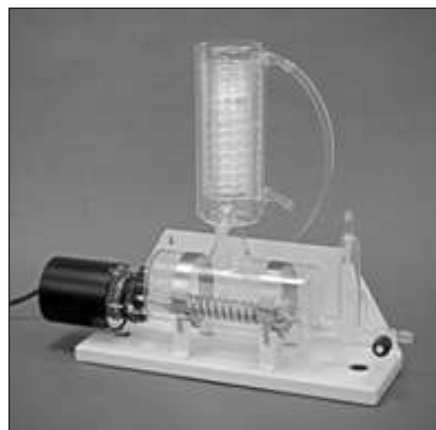
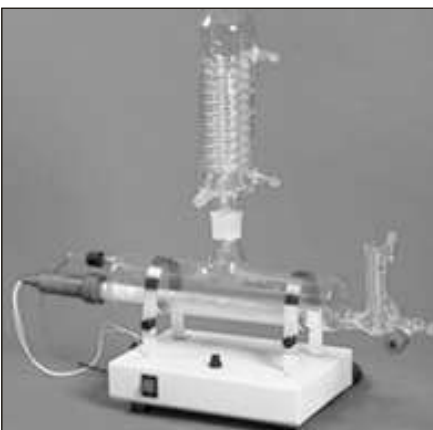

VALUABLE CLIENTS



CERTIFICATE





Industries We Serve...

- Pharmaceutical and bulk drug industry
- Industrial Chemicals
- Dyes and dye intermediate
- Specialty Chemicals
- Petrochemicals
- Agrochemicals
- Research and development units
- Herbal
- Aroma c chemicals
- Pesticides



Shiva Scientific Glass Pvt. Ltd.

Regd. & Head Office : GH-8/350, Paschim Vihar,
New Delhi-110 087, INDIA.

M : 9810185023, 9310185023

E : delhi@shivascientificindia.com

E : boro.scientific@gmail.com

W : www.shivascientificindia.com

Unit I : 'B' Wing, 36-1-A, GIDC, Makarpura,
Vadodara-390010, Gujarat (INDIA)

M : 9810185024

E : sales@shivascientificindia.com

E : borog65@yahoo.com

Unit II : 31 A, Syed Village,
Paschim Vihar, New Delhi-110087 (INDIA)

M : 9310185024

Branch Office : Mumbai, Hyderabad, Banglore, Chennai, Chandigarh